

ENGINE PRO

Performance Parts Catalog



WHERE TO BUY

EPG LOCATIONS

ALABAMA

BOAZ 256-593-2289 866-815-2289

ALASKA

ANCHORAGE 907-563-7278 800-288-5573

ARIZONA

PHOENIX-W. WINDSOR 602-272-0191 888-272-0191

PHOENIX-N. 22ND AVE. 602-258-1161 800-827-7727

CALIFORNIA

LOS ANGELES-GARDENA 323-318-7070 800-972-0900

LOS ANGELES-VERNON 323-582-2205 800-995-0536

OAKLAND 510-569-9802 800-234-1410

RIVERSIDE 951-682-6085 800-244-3351

SACRAMENTO 916-920-2221 800-367-6717

SAN DIEGO 619-336-9770 800-995-2060

COLORADO

DENVER 303-572-8844 800-888-8970

FLORIDA

DANIA BEACH 945-862-1500 888-750-5487

JACKSONVILLE 904-356-9422 800-342-2785

MIAMI NPW HQ 305-953-7300 800-344-0368

ORLANDO 407-422-5555 800-432-3487

SOUTH DADE 305-263-8220 800-344-0368

TAMPA 727-531-9353 800-284-9815

OAKLAND PARK 954-561-3622 800-344-0368

IDAHO

BOISE 208-342-6868 800-366-8851

IDAHO FALLS 208-523-5892 800-366-8851

ILLINOIS

CHICAGO SOUTH 312-842-2259 800-621-1542

CHICAGO NORTH 773-889-4500 800-878-7938

MASSACHUSETTS

WORCESTER 508-752-2263 800-225-7208

MICHIGAN

GRAND RAPIDS 616-247-6572 800-942-0983

LIVONIA 734-524-9208 800-482-1052

MINNESOTA

MINNEAPOLIS 612-623-3921 888-765-5487

MISSOURI

KANSAS CITY 816-842-1887 800-821-5148

NEW MEXICO

ALBUQUERQUE 505-761-0100 877-767-0100

Visit our website at
www.enginepro.com

OHIO

CINCINNATI 513-821-0444

OKLAHOMA

OKLAHOMA CITY 405-942-8435 800-937-3652

OREGON

PORTLAND-TUALATIN 503-691-6251 800-876-5152

PORTLAND-HILLSBORO 503-417-5300 800-999-2989

PENNSYLVANIA

PITTSBURGH 412-361-3493 800-842-7265

RHODE ISLAND

NPW PROVIDENCE 401-384-6010 800-556-2864

SOUTH CAROLINA

ANDERSON 864-226-7039 800-274-2825

GREENVILLE 864-295-3360 800-274-2825

TENNESSEE

MEMPHIS 901-480-4431 866-917-4728

TEXAS

DALLAS-CASH RD. 214-637-4361 800-284-5348

DALLAS-CALVERT ST. 214-637-6355 800-888-6958

HOUSTON 713-862-2929 800-288-6548

SAN ANTONIO 210-224-8424 800-423-2707

UTAH

SALT LAKE CITY 801-973-6842 800-366-8851

WASHINGTON

TACOMA-N.9TH ST. 253-597-6075 800-999-2989

TACOMA-PORTLAND AVE. 800-876-5152

CANADA

TORONTO 905-619-6662 888-527-2358



AUSTRALIA

HEAD OFFICE 03 9797 1131

NEW SOUTH WALES 02 9612 2600

QUEENSLAND 07 3717 7300

SOUTH AUSTRALIA 08 8368 3700

VICTORIA 03 9797 1115

WESTERN AUSTRALIA 08 9395 4500

NETHERLANDS/EUROPE

WILMINK GROUP +31 (0) 6 50 48 97 90

INDEX BY PRODUCT

ASSEMBLY LUBES	65
BOLT BOOTS	51
CAM LOCK PLATES	44
CAMSHAFTS	30-36
CAMSHAFT BUTTONS	44
CAMSHAFT DEGREE BUSHINGS	44
CAMSHAFT THRUST PLATES	44
CLEANERS	66
CONNECTING RODS & BOLTS	51
DISTRIBUTOR GEARS	45
ENGINE BAGS	66
ENGINE BEARINGS	48-50
GASKETS	60-63
GUIDE PLATES	13
HARDWARE KITS	58
HARMONIC BALANCERS	47
HARMONIC BALANCER BOLTS	46-47
HEAD BOLTS	62
HEAT TABS	66
HONING OIL	66
LASH CAPS	13
LIFTER VALLEY SCREEN KITS	59
LIFTER VALLEY VENT KIT	59
MAGNET KIT	59
OIL ADDITIVE	65
OIL FILTER ADAPTER	58
OIL RESTRICTORS	59
PAINTS	64
PISTON RINGS	52-57
POLYLOCKS	15
PUSHRODS	16-18
PUSHROD CHECKING TOOL KIT	18
REAR MAIN SEAL HOUSINGS	58
ROCKER ARM STUDS	15
ROLLER ROCKER ARMS	14
ROTATOR ELIMINATORS	11
TIMING COVERS	45-46
TIMING COVER STUD KITS	46
TIMING POINTERS	46
TIMING SETS	37-43
TIMING TENSIONERS & DAMPERS	45
TRANSMISSION DOWELS	58
TRUNNION KIT	15
VALVES	4-7
VALVE LIFTERS	19-29
VALVE LOCKS	13
VALVE SPRING CUPS	11
VALVE SPRINGS	8-9
VALVE SPRING LOCATORS	11
VALVE SPRING RETAINERS	10
VALVE SPRING SHIMS	11
VALVE STEM SEALS	12
WINDAGE TRAY	61

BY PRODUCT CATEGORY

VALVE TRAIN	4-18
CAMS, LIFTERS AND TIMING	19-45
HARMONIC BALANCERS AND POINTERS	46-47
BEARINGS AND CONNECTING RODS	48-51
PISTON RINGS	52-57
BLOCK ACCESSORIES	58-59
GASKETS	60-63
PAINTS, CHEMICALS AND LUBES	64-66



ABOUT THIS CATALOG

ENGINE PRO PERFORMANCE PRODUCTS Every year, the Engine Pro line of performance engine parts gets deeper and wider but the basic Engine Pro principle has never changed. We offer engine professionals the highest quality performance engine parts at excellent prices so they can make a good profit on their parts.

With 98 warehouses, Engine Pro is the largest engine parts distribution network in the U.S. with distribution in Canada, Europe and Australia. Engine Pro offers more than 100 premium brands including its own Engine Pro and Nitro Black products for performance, domestic, import, agricultural, marine and heavy-duty applications.



ENGINE PRO PERFORMANCE PARTS WARRANTY DISCLAIMER

Due to the nature of performance applications, the parts in this catalog are sold without any expressed warranty or any implied warranty of merchantability or fitness for a particular purpose. Engine Pro (Engine Parts Group, Inc.) shall not, under any circumstances, be liable for any special, incidental, or consequential damages including but not limited to damage or loss of other property or equipment, loss of profits or revenue, cost of purchased or replaced parts, or claims of customers of the purchaser, which may arise or result from the sale, installation, or use of these parts.

Installation of these parts may affect the vehicle manufacturers warranty.

NOTE: It is illegal to use Engine Pro performance camshafts in vehicles that are operated on the public streets and highways of California. Various other federal and state laws may limit the use of these camshafts to "off highway" applications only. Check current state and federal laws to be sure.

NITRO BLACK PERFORMANCE VALVES

Our proprietary liquid nitriding process creates a valve that is smoother, stronger and more corrosion resistant than traditional chromed valves, even with exotic fuels.

Our deep nitriding provides better ductility under the hard nitrided layer and is proven in rotating-bending fatigue tests.

These valves are less likely to break even if contacted by the piston and greater surface hardness means less valve guide wear.

- One piece forging in 21-4N high strength stainless alloy
- Swirl polished for improved flow characteristics
- Fully undercut stem
- Hard wafer tip

WATCH THE NITRO BLACK PERFORMANCE VALVE VIDEO



APPLICATION	HEAD DIAMETER	STEM DIAMETER	INSTALLED HEIGHT	OVERALL LENGTH	TIP LENGTH	PART #
CHEVROLET SMALL BLOCK						
EXHAUST	1.500	11/32"	STOCK	4.910	.250	01-3000-8*
	1.600	11/32"	STOCK	4.910	.250	01-3001-8
	1.600	11/32"	+100	5.010	.250	01-3001.100-8
INTAKE	1.940	11/32"	STOCK	4.910	.250	01-3002-8*
	2.020	11/32"	STOCK	4.910	.250	01-3003-8
	2.020	11/32"	+100	5.010	.250	01-3003.100-8
	2.055	11/32"	+100	5.010	.250	01-3007.100-8
	2.080	11/32"	+100	5.010	.250	01-3008.100-8
* No undercut						
CHEVROLET BIG BLOCK						
EXHAUST	1.880	3/8"	STOCK	5.352	.250	01-3004-8
	1.880	11/32"	+100	5.452	.250	01-3014.100-8
	1.880	11/32"	+100	5.452	.250	01-3015.100-8*
	1.880	11/32"	+150	5.502	.250	01-3014.150-8
INTAKE	2.190	3/8"	STOCK	5.228	.250	01-3005-8
	2.250	11/32"	+250	5.478	.250	01-3012.250-8
	2.300	11/32"	+250	5.478	.250	01-3013.250-8
	2.300	11/32"	+300	5.525	.250	01-3013.300-8
* 20° No undercut						
CHEVROLET LS1- BEAD LOCK						
EXHAUST	1.570	.313	STK	4.890	.160	01-3200-8
	1.600	.313	STK	4.890	.160	01-3201-8
INTAKE	2.020	.314	STK	4.880	.160	01-3202-8
	2.041	.314	STK	4.880	.160	01-3206-8
	2.055	.314	STK	4.880	.160	01-3207-8

Scanning Electron Microscope Comparison



Surface Texture Tests (Roughness measurement)

Nitro Black Rp:38.5 micro inches

Chrome Rp:48.8 micro inches

Laboratory tests prove that NITRO BLACK nitrided performance valves are more than 21% smoother than traditional chrome plated valves. Scanning electron microscope images back that up.

Smoother valve stems mean less valve and valve guide friction.

Less friction means more power, less wear and less chance of breakage.

Our nitriding process is much cleaner than chroming- it's better for the environment!

NITRO BLACK DIESEL PERFORMANCE VALVES



Features

- Exhaust valves are bi-metallic and made from Inconel and HNV-3 alloys
- Intake valves are made from high strength 21-4N stainless steel alloy
- Stellite facing creates additional heat resistance on the head of both valves
- Liquid nitriding strengthens the entire valve not just the surface area
- Better ductility makes the valve less likely to break, even if contacted by a piston
- Greater surface hardness reduces crack formation
- Smoother surface means less valve and guide wear
- Resists corrosion and deposits caused by exotic fuels

Engine Pro Diesel Performance valves are designed to perform reliably in the extreme conditions that exist in highly boosted turbocharged diesel engines.

Both intake and exhaust valves are put through our proprietary five step liquid nitriding process, resulting in valves that are smoother, stronger and more corrosion resistant than traditional chrome plated stainless valves.



WATCH THE NITRO BLACK DIESEL VALVE VIDEO



APPLICATION	TYPE	HEAD DIAMETER	STEM DIAMETER	OVERALL LENGTH	TIP LENGTH	SEAT ANGLE	PART #
DODGE/CUMMINS ISB 5.9L 5.9L - 6.7L TURBO (98-15) 24 VALVES	EXH	1.299	.2756	4.893	.299	45 DEG.	01-4991-12
	INT	1.299	.2756	4.907	.299	30 DEG.	01-4990-12
FORD 6.0L POWERSTROKE NAVISTAR TURBO (03-10) 32 VALVES	EXH	1.102	.2738	5.059	.358	37 DEG.	01-4985-8
	INT	1.139	.2738	5.059	.358	30 DEG.	01-4984-8
FORD 6.4L POWERSTROKE NAVISTAR TURBO (08-10) 32 VALVES	EXH	1.161	.2734	5.138	.433	39.3 DEG.	01-4987-8
	INT	1.339	.2736	5.138	.433	37 DEG.	01-4986-8
FORD 6.7L POWERSTROKE FORD TURBO (2011 - ON) 32 VALVES	EXH	1.195	.2748	5.242	.699	44.5 DEG.	01-4989-8
	INT	1.331	.2748	5.242	.699	29.3 DEG.	01-4988-8
FORD 7.3L POWERSTROKE NAVISTAR 444TE TURBO (94-03) 16 VALVES	EXH	1.681	.3122	5.801	.289	37.3 DEG.	01-4983-8
	INT	1.681	.3122	5.798	.339	30 DEG.	01-4982-8
GM 6.6L DURAMAX DD (01-16) 32 VALVES	EXH	1.220	.2730	4.965	.519	45 DEG.	01-4995-8
	INT	1.299	.2741	4.975	.519	45 DEG.	01-4994-8

NOTE: 32 valve engines require 2 boxes of 8 exhaust valves and 2 boxes of 8 intake valves to replace valves in complete engine

PERFORMANCE INCONEL ALLOY VALVES

- For marine, supercharged and turbocharged applications
- Exotic alloy designed to function in extreme heat conditions
- One piece forging
- Swirl polished for improved flow characteristics
- Hard wafer tip

WATCH THE ENGINE PRO RACING STAINLESS VALVES VIDEO



APPLICATION	HEAD DIAMETER	STEM DIAMETER	INSTALLED HEIGHT	OVERALL LENGTH	TIP LENGTH	PART #
CHEVROLET BIG BLOCK INCONEL EXHAUST VALVES	1.890	3/8"	+.050	5.400	.250	01-4301-8
	1.880	11/32"	+.100	5.450	.250	01-4312-8
	1.900	11/32"	+.100	5.450	.250	01-4313-8

RACING STAINLESS VALVES

2000 SERIES

- High strength stainless alloy (21-4N)
- Undercut stem
- One piece forging
- Swirl polished for improved flow
- Hardened tip
- Hard chrome plated stem



SEE OUR RACING STAINLESS VALVE VIDEO



TYPE	HEAD DIA.	STEM DIA.	INSTALLED HEIGHT	OVERALL LENGTH	TIP LENGTH	REFERENCE INFORMATION	PART #
CHEVROLET SMALL BLOCK							
EXHAUST	1.500	11/32"	STOCK	4.910	.250	12° UNDERCUT, FLOW	01-2000-8
	1.500	11/32"	+ .050	4.960	.250	12° NO UNDERCUT	01-2062.050-8
	1.600	11/32"	STOCK	4.910	.250	12° UNDERCUT, FLOW STOCK	01-2001-8
	1.600	11/32"	+ .050	4.960	.250	12° UNDERCUT, SUPER FLOW, EDELBROCK HEAD	01-2001.050-8
	1.600	11/32"	+ .100	5.010	.250	12° UNDERCUT, SUPER FLOW	01-2001.100-8
	1.600	11/32"	+ .150	5.060	.250	12° UNDERCUT	01-2001.150-8
	1.600	11/32"	+ .250	5.160	.250	15° UNDERCUT	01-2001.250-8
INTAKE	1.940	11/32"	STOCK	4.910	.250	12° UNDERCUT	01-2002-8
	1.940	11/32"	+ .050	4.960	.250	12° UNDERCUT	01-2002.050-8
	1.940	11/32"	+ .050	4.960	.250	12° NO UNDERCUT	01-2061.050-8
	2.020	11/32"	STOCK	4.910	.250	12° UNDERCUT	01-2003-8
	2.020	11/32"	+ .100	5.010	.250	12° UNDERCUT, SUPER FLOW	01-2003.100-8
	2.055	11/32"	+ .100	5.010	.250	12° UNDERCUT, SUPER FLOW	01-2007.100-8
	2.055	11/32"	+ .150	5.060	.250	12° UNDERCUT, SUPER FLOW	01-2007.150-8
	2.080	11/32"	+ .100	5.010	.250	12° UNDERCUT, SUPER FLOW	01-2008.100-8
	2.080	11/32"	+ .150	5.060	.250	12° UNDERCUT	01-2008.150-8
CHEVROLET BIG BLOCK							
EXHAUST	1.880	3/8"	STOCK	5.352	.250	15° UNDERCUT, SUPER FLOW	01-2004-8
	1.880	11/32"	+ .100	5.421	.250	15° UNDERCUT, SUPER FLOW, BRODIX/DART 320-360	01-2014.100-8
	1.880	11/32"	+ .150	5.471	.250	15° UNDERCUT, SUPER FLOW	01-2014.150-8
INTAKE	2.190	3/8"	STOCK	5.221	.225	12° UNDERCUT, SUPER FLOW	01-2005-8
	2.250	11/32"	+ .100	5.355	.250	12° UNDERCUT, SUPER FLOW	01-2012.100-8
	2.250	11/32"	+ .250	5.471	.250	12° UNDERCUT, SUPER FLOW	01-2012.250-8
	2.300	11/32"	+ .250	5.471	.250	12° UNDERCUT, SUPER FLOW, BRODIX/DART 320-360	01-2013.250-8
CHEVROLET LS							
EXHAUST	1.550	.3130	STOCK	4.915	.160	15° LS1, NO UNDERCUT, RADIUS GROOVE	01-2204-8
	1.570	.3130	STOCK	4.915	.160	25° TULIP LS1, UNDERCUT, RADIUS GROOVE	01-2200-8
	1.600	.3130	STOCK	4.915	.160	15° LS1, UNDERCUT, RADIUS GROOVE	01-2201-8
INTAKE	2.000	.3130	STOCK	4.900	.160	12° LS1, UNDERCUT, RADIUS GROOVE	01-2220-8
	2.020	.3137	STOCK	4.900	.160	10° LS1, UNDERCUT, RADIUS GROOVE	01-2202-8
	2.165	.3137	STOCK	4.900	.160	12° LS3, BACK CUT, 30° RADIUS GROOVE	01-2231-8
	2.200	.3137	STOCK	4.900	.160	12° LS3, BACK CUT, 30° RADIUS GROOVE	01-2232-8
FORD 4.6 - 32 VALVES							
EXHAUST	30MM	7MM	STOCK	117.1MM	10.65MM	25° SUPER FLOW, 3 RADIAL GROOVES	01-2147-8
INTAKE	37MM	7MM	STOCK	135.9MM	15.70MM	20° SUPER FLOW, 3 RADIAL GROOVES	01-2146-8
FORD FE							
EXHAUST	1.655	3/8"	STOCK	5.435	.330	12° SUPER FLOW, EDELBROCK HEAD	01-2301-8
INTAKE	2.090	3/8"	STOCK	5.450	.330	22° SUPER FLOW, 30° SEAT, EDELBROCK HEAD	01-2300-8

PERFORMANCE STAINLESS VALVES

- Undercut stem
- Fully machined
- Hardened tip
- One piece forging
- Stainless steel alloy
- Hard chrome plated stem

500 & 1000 SERIES



SEE OUR RACING STAINLESS VALVE VIDEO

TYPE	HEAD DIA.	STEM DIA.	INSTALLED HEIGHT	OVERALL LENGTH	TIP LENGTH	REFERENCE INFORMATION	500 ECONOMY	PART #
CHEVROLET SMALL BLOCK								
EXHAUST	1.500	11/32"	STOCK	4.910	.250	12° UNDERCUT, DISH HEAD	01-500-8	01-1000-8
	1.500	11/32"	+100	5.010	.256	12° UNDERCUT		01-1000.100-8
	1.600	11/32"	STOCK	4.910	.250	12° UNDERCUT, DISH HEAD	01-501-8	01-1001-8
	1.600	11/32"	+100	5.010	.250	12° UNDERCUT, DISH HEAD		01-1001.100-8
	1.650	11/32"	+150	5.060	.250	12° UNDERCUT, DISH HEAD		01-1052.150-8
	INTAKE	1.940	11/32"	STOCK	4.910	.250	10° UNDERCUT, DISH HEAD	01-502-8
1.940		11/32"	+100	5.010	.256	10° UNDERCUT		01-1002.100-8
	2.020	11/32"	STOCK	4.910	.250	10° UNDERCUT, DISH HEAD	01-503-8	01-1003-8
	2.020	11/32"	+100	5.010	.250	10° UNDERCUT, DISH HEAD		01-1003.100-8
	2.055	11/32"	STOCK	4.910	.250	10° UNDERCUT, DISH HEAD		01-1007-8
	2.055	11/32"	+100	5.010	.250	10° UNDERCUT, DISH HEAD		01-1007.100-8
	2.080	11/32"	STOCK	4.910	.250	10° UNDERCUT, DISH HEAD		01-1008-8
	2.080	11/32"	+100	5.010	.250	10° UNDERCUT, DISH HEAD		01-1008-100-8
CHEVROLET BIG BLOCK								
EXHAUST	1.720	3/8"	STOCK	5.352	.250	12° UNDERCUT, DISH HEAD		01-1011-8
	1.880	3/8"	STOCK	5.352	.250	12° UNDERCUT, DISH HEAD		01-1004-8
	1.880	11/32"	+100	5.425	.250	12° UNDERCUT, DISH HEAD		01-1014.100-8
	INTAKE	2.190	11/32"	+100	5.300	.250	10° UNDERCUT, DISH HEAD	
2.065		3/8"	STOCK	5.228	.250	10° UNDERCUT, DISH HEAD		01-1010-8
	2.190	3/8"	STOCK	5.228	.250	10° UNDERCUT, DISH HEAD		01-1005-8
	2.250	3/8"	STOCK	5.271	.225	10° UNDERCUT, DISH HEAD		01-1032-8
CHRYSLER SMALL BLOCK 340, W2								
EXHAUST	1.600	3/8"	+070	5.075	.225	14° UNDERCUT		01-1600.070-8
INTAKE	2.020	3/8"	+050	5.050	.225	12° UNDERCUT		01-1602.050-8
CHRYSLER BIG BLOCK								
EXHAUST	1.740	3/8"	STOCK	4.910	.290	14° UNDERCUT		01-1311-8
INTAKE	2.080	3/8"	STOCK	4.875	.290	12° UNDERCUT		01-1310-8
FORD SMALL BLOCK, 351W & GT40 HEAD								
EXHAUST	1.460	11/32"	STOCK	5.070	.395	12° UNDERCUT, DISH HEAD		01-1102-8
	1.550	11/32"	STOCK	5.075	.395	12° UNDERCUT, DISH HEAD		01-1105-8
	1.600	11/32"	STOCK	5.075	.395	12° UNDERCUT, DISH HEAD		01-1155-8
INTAKE	1.780	11/32"	STOCK	5.070	.395	10° UNDERCUT, DISH HEAD		01-1101-8
	1.940	11/32"	STOCK	5.075	.395	10° UNDERCUT, DISH HEAD		01-1106-8
FORD 351C, BOSS 302, 429, 460								
EXHAUST	1.710	11/32"	STOCK	5.060	.250	12° UNDERCUT, DISH HEAD		01-1108-8
	1.760	11/32"	STOCK	5.060	.250	9° FLOW, DISH HEAD		01-1109-8
INTAKE	2.070	11/32"	STOCK	5.275	.250	12° UNDERCUT, DISH HEAD		01-1110-8
	2.190	11/32"	+025	5.300	.250	10° UNDERCUT, DISH HEAD		01-1115.100-8
	2.250	11/32"	STOCK	5.271	.250	10° UNDERCUT, DISH HEAD		01-1107.050-8
PONTIAC 400-455								
EXHAUST	1.770	11/32"	STOCK	5.110	.250	9° FLOW, DISH HEAD		01-1500-8
INTAKE	2.110	11/32"	STOCK	5.095	.250	9° FLOW, DISH HEAD, 30° SEAT		01-1501-8

NITRO BLACK BEEHIVE VALVE SPRINGS

Super Clean Chrome Silicon Vanadium Nickel Alloy



See Beehive Retainers
See pg 10

- Beehive shaped design allows a reduced retainer end mass for improved RPM potential
- Every spring goes through a multiple shot peening process to ensure maximum durability and stress relief
- “Heat Set” process and special heat treatment are used to extend spring life and minimize load loss
- Ovate wire shape more evenly distributes mass throughout the wire cross section

SPRING O.D. BOTTOM	SPRING I.D. BOTTOM	SPRING O.D. TOP	SPRING I.D. TOP	CLOSED HEIGHT	CLOSED LOAD	OPEN HEIGHT	OPEN LOAD	COIL BIND	MAX. LIFT	RATE	PART #
1.061	0.737	0.960	.636	1.640	80	1.090	185	1.020	.550	191	02-1200-16
1.237	0.825	1.062	.650	1.700	110	1.175	292	1.115	.575	347	02-1205-16
1.292	0.880	1.062	.650	1.800	135	1.150	330	1.110	.650	300	02-1201-16
1.292	0.880	1.062	.650	1.800	105	1.200	298	1.100	.625	322	02-1204-16
1.412	1.065	1.000	.650	1.750	123	1.175	284	1.100	.650	284	02-1203-16
1.447	0.999	1.098	.650	1.880	155	1.280	365	1.210	.600	350	02-1202-16

*Cr-Si-V-Ni = Chrome Silicon Vanadium Nickel Alloy

SUPER CLEAN STREET/RACE VALVE SPRINGS

Dual Valve Spring Assemblies

All Engine Pro valve springs are manufactured using the highest quality chrome silicon or high tensile chrome silicon vanadium alloy materials. Our springs are inspected during the manufacturing process to ensure consistent dimensions and overall quality.

- Every spring goes through a multiple shotpeening process for maximum durability and stress relief
- “Heat Set” process and special heat treatment are used to extend spring life and minimize load loss



OUTER SPRING O.D.	OUTER SPRING I.D.	INNER SPRING I.D.	CLOSED HEIGHT	CLOSED LOAD	OPEN HEIGHT	OPEN LOAD	COIL BIND	MAX. LIFT	RATE	MATERIAL TYPE *	DAMPER	RETAINER CODE PG. 10	PART#
1.304	0.940	.670	1.800	151	1.150	417	1.080	.650	409	CR-SI-V	N	H	02-1023-16*
NOTE: *THIS SPRING IS SPECIFICALLY DESIGNED FOR CHEVROLET LS ENGINE APPLICATIONS													
1.304	0.940	.670	1.800	151	1.150	417	1.080	.650	409	CR-SI-V	N	H	02-2023-16*
NOTE: *SIMILAR TO #02-1023-16. FEATURES FINAL GLASS BEAD SHOTPEENING TO ENHANCE FATIGUE LIFE AND EXTRA SMOOTH GROUND ENDS													
1.385	0.995	.711	1.850	161	1.250	430	1.195	.600	448	CR-SI	N	H	02-1301-16
1.388	1.062	.806	1.600	117	1.100	232	1.000	.600	230	CR-SI-V	N	C	02-1024-16
1.440	1.076	.697	1.700	126	1.150	364	1.055	.550	433	CR-SI	Y	C, D	02-1010-16
1.445	1.085	.697	1.750	142	1.150	349	1.055	.600	345	CR-SI	Y	C, D	02-1003-16
1.445	1.085	.696	1.750	133	1.150	316	1.055	.600	305	CR-SI	Y	C, D	02-1004-16
1.450	1.060	.790	1.900	140	1.300	358	1.120	.650	363	CR-SI	N	C, D	02-1300-16
1.460	1.060	.696	1.850	126	1.250	368	1.150	.625	403	CR-SI	Y	C, D	02-1011-16
1.515	1.115	.696	1.900	125	1.200	385	1.165	.725	371	CR-SI	Y	C, D, F	02-1012-16
1.539	1.125	.697	1.950	145	1.350	425	1.200	.625	467	CR-SI	Y	F	02-1015-16
1.539	1.125	.731	1.900	206	1.250	520	1.200	.650	483	CR-SI	Y	F, G	02-1008-16
1.546	1.134	.814	1.900	240	1.250	598	1.150	.650	551	CR-SI-V	N	E	02-1009-16

*Cr-Si = Chrome Silicon Alloy. Cr-Si-V = Chrome Silicon Vanadium Alloy

SUPER CLEAN STREET/RACE VALVE SPRINGS

Single Valve Springs

- Every spring goes through a multiple shotpeening process for maximum durability and stress relief
- “Heat Set” process and special heat treatment are used to extend spring life and minimize load loss



SPRING O.D.	SPRING I.D.	CLOSED HEIGHT	CLOSED LOAD	OPEN HEIGHT	OPEN LOAD	COIL BIND	MAX. LIFT	RATE	MATERIAL TYPE *	DAMPER	RETAINER CODE PG. 10	PART#
0.995	0.657	1.880	90	1.400	260	1.300	.525	354	CR-SI	N		02-4040-32*
NOTE: *THIS SPRING IS SPECIFICALLY DESIGNED FOR FORD 6.0-6.4L DIESEL APPLICATIONS												
1.230	0.876	1.700	91	1.250	233	1.150	.525	316	CR-SI	Y	A	02-1000-16
1.253	0.870	1.700	124	1.210	322	1.160	.490	404	CR-SI	Y	A	02-1001-16
1.259	0.876	1.750	128	1.200	325	1.160	.550	358	CR-SI	N	A	02-2002-16*
NOTE: *THIS SPRING IS SPECIFICALLY DESIGNED FOR CHEVROLET 305-350 VORTEC APPLICATIONS												
1.259	0.876	1.800	121	1.200	365	1.160	.600	407	CR-SI	Y	A	02-1002-16
1.263	0.880	1.750	150	1.250	367	1.100	.500	434	CR-SI-V	Y	A	02-1016-16
1.354	0.940	1.850	97	1.350	312	1.280	.550	430	CR-SI	Y	H	02-1019-16
1.437	1.035	1.700	110	1.200	289	1.060	.550	358	CR-SI	Y	B	02-1017-16
1.463	1.080	1.900	100	1.300	252	1.120	.650	253	CR-SI	Y	C, D	02-1020-16
1.464	1.064	1.800	129	1.250	305	1.135	.550	320	CR-SI	Y	C, D	02-1021-16
1.476	1.062	1.800	109	1.300	317	1.140	.525	416	CR-SI	Y	C, D	02-1005-16
1.494	1.080	1.650	106	1.250	258	1.100	.525	380	CR-SI	Y	C, D	02-1022-16
1.500	1.117	1.850	137	1.150	355	1.050	.575	289	CR-SI-V	Y	E, F, G	02-1018-16
1.539	1.125	1.900	133	1.400	309	1.170	.625	352	CR-SI	Y	E, F, G	02-1007-16
1.548	1.134	1.900	150	1.350	328	1.180	.575	324	CR-SI	Y	E, F, G	02-1014-16

*Cr-Si = Chrome Silicon Alloy. Cr-Si-V= Chrome Silicon Vanadium Alloy

ENGINE PRO LS DROP-IN VALVE SPRINGS

OEM Replacement High Performance Beehive Spring

- This is the Brown spring, replaces previous Blue spring
- OEM # 12713625 replaces previous #12625033, factory performance and crate motors



SPRING O.D. BOTTOM	SPRING I.D. BOTTOM	SPRING O.D. TOP	SPRING I.D. TOP	CLOSED HEIGHT	CLOSED LOAD	OPEN HEIGHT	OPEN LOAD	COIL BIND	MAX. LIFT	RATE	PART#
1.270	0.845	.985	.645	1.800	90	1.200	295	1.230	.570	342	02-3625-16

ENGINEPROSHOPSOLUTIONS.COM



LATEST SHOP SOLUTIONS EASY HEIGHT TRANSFER

When setting up valve springs or checking valve spring pressure I set a spring retainer on my Height Mic and use that to check the springs on the tester. To figure the installed height, bring the tester to the desired pressure and open the Height Mic to match and that's your target installed height. In reverse you can see where the spring pressure is on the heads now. It is easy and quick.

Randy Torvinen Torvinen's Machine Menahga, MN February, 2020



WATCH THE ENGINE PRO VALVE SPRINGS VIDEO

TITANIUM VALVE SPRING RETAINERS

Engine Pro titanium valve spring retainers are engineered to perform under the most extreme conditions and are inspected to ensure precise tolerances.

- Manufactured from 6AL4V titanium alloy
- Made in the USA
- Light weight
- Machined and polished finish

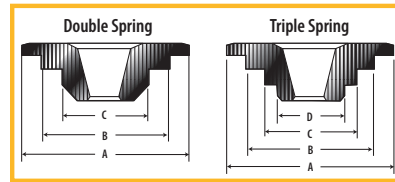

SPRING O.D.	SPRING TYPE	VALVE STEM SIZE	DIMENSIONS				KEEPER DEGREE	SPRING CODE	PART #
			A	B	C	D			
1.275/1.325	DOUBLE	8MM	1.240	0.940	.640		7	H	03-1717-16
1.437 / 1.500	DOUBLE	ALL	1.437	1.065	.700		10	C	03-1730-16
1.500 / 1.550	DOUBLE	ALL	1.437	1.100	.800		10	E	03-1731-16
1.500 / 1.550	DOUBLE	ALL	1.500	1.110	.710		10	F	03-1732-16
1.625	DOUBLE	ALL	1.500	1.180	.765		10	I	03-1733-16
1.500 / 1.550	TRIPLE	ALL	1.500	1.135	.835	.635	10	O	03-1736-16
1.625	TRIPLE	ALL	1.500	1.180	.870	.635	10	P	03-1739-16
1.625	TRIPLE	ALL	1.500	1.180	.870	.635	10	P	03-1735-16*
1.300	BEEHIVE	ALL	1.050	0.640			10		03-1794-16

*+.050 installed height over # 03-1739

STEEL VALVE SPRING RETAINERS

Engine Pro chromoly steel retainers are designed to handle high pressures developed by new large diameter valve springs. Our retainers are manufactured to precise tolerances to ensure the springs are located properly. Available for 7 degree and 10 degree valve locks.

- 4140 chromoly steel alloy
- Heat treated
- CNC machined
- Black oxide finish

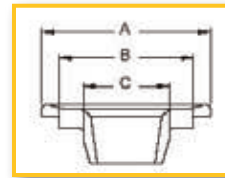

SPRING O.D.	SPRING HEIGHT	KEEPER DEGREE	VALVE STEM SIZE	DIMENSIONS			SPRING CODE	PART #
				A	B	C		
1.250	STD	7	11/32"	1.245	0.865	.680	A	03-1000-16
1.250	+.050	7	11/32"	1.245	0.865	.680	A	03-1001-16
1.275/1.325	STD	7	8MM	1.240	0.940	.640	H	03-1017-16
1.437/1.500	STD	7	11/32"	1.400	1.030	.690	B	03-1016-16
1.437/1.550	STD	7	11/32"	1.440	1.050	.700	C	03-1003-16
1.437/1.550	+.100	7	11/32"	1.440	1.050	.700	C	03-1010-16
1.437/1.550	STD	7	3/8"	1.440	1.050	.700	D	03-1005-16
1.437/1.550	STD	10	ALL	1.440	1.050	.700	D	03-1002-16
1.437/1.500	STD	10	ALL	1.400	1.060	.690	D	03-1006-16
1.500/1.550	STD	10	ALL	1.437	1.100	.800	E	03-1004-16
1.500/1.550	+.100	10	ALL	1.500	1.115	.690	F	03-1007-16
1.550	+.100	10	ALL	1.500	1.105	.710	G	03-1008-16
1.550	+.100	10	ALL	1.500	1.120	.705	G	03-1009-16
0.959	STD	7	STOCK	0.930	0.630	BEEHIVE	MOD FORD	03-1012-16
1.055	STD	7	8MM	1.030	0.640	BEEHIVE	GM LS	03-1011-16
1.055	STD	7	8MM	1.030	0.640	BEEHIVE	GM LS	03-1015-16*
1.055	STD	7	11/32"	1.030	0.640	BEEHIVE	UNIVERSAL	03-1013-16
1.095	STD	10	ALL	1.050	0.640	BEEHIVE	UNIVERSAL	03-1014-16

* Same as 03-1011 but I.D. is machined for additional valve guide clearance.

O.D. VALVE SPRING CUPS

Ensure proper spring location and long life even under extreme spring pressure conditions.

- CNC machined
- Heat treated 4140 steel
- Black oxide coated



SPRING O.D.	CUP O.D.	CUP I.D.	SHOULDER HEIGHT	THICKNESS	PART #
1.250	1.390	.570	.150	.062	03-2000-16
1.437	1.550	.687	.150	.062	03-2001-16
1.480	1.570	.640	.150	.062	03-2009-16
1.550	1.680	.635	.150	.062	03-2002-16
1.550	1.740	.635	.158	.062	03-2006-16
1.560	1.740	.635	.128	.152	03-2007-16
1.625	1.740	.635	.150	.062	03-2004-16
1.650	1.740	.635	.183	.037	03-2008-16
1.660	1.740	.635	.140	.062	03-2005-16

I.D. VALVE SPRING LOCATORS

Close tolerances are maintained to ensure proper spring location under extreme spring pressure conditions.

- 8620 Steel heat treated
- CNC machined +/- .002"
- Black oxide finish



SPRING O.D.	LOCATOR O.D.	LOCATOR I.D.	CUP THICKNESS	SHOULDER HEIGHT	SHOULDER DIA.	PART #
N/A	1.230	.535	.062	.140	.782	03-3012-16
N/A	1.245	.520	.065	.117	.636	03-3013-16
N/A	1.247	.563	.057	.146	.654	03-3014-16
N/A	1.300	.520	.065	.117	.636	03-3015-16
N/A	1.300	.505	.060	.125	.640	03-3016-16
1.300	1.300	.570	.062	.198	.655	03-3010-16
1.480	1.480	.570	.060	.210	.690	03-3011-16
1.550	1.535	.570	.062	.140	.740	03-3001-16
1.560	1.550	.567	.062	.163	.802	03-3002-16
1.560	1.550	.560	.060	.185	.690	03-3003-16
1.580	1.570	.567	.062	.163	.828	03-3004-16
1.580	1.570	.567	.045	.163	.828	03-3005-16
1.620	1.620	.570	.060	.185	.760	03-3006-16
1.625	1.615	.570	.062	.140	.675	03-3007-16
1.625	1.570	.567	.062	.163	.850	03-3008-16
1.660	1.660	.570	.062	.140	.630	03-3009-16

PERFORMANCE HARDENED VALVE SPRING SHIMS

Ensures proper spring pressure and assembled height after valve and valve seat reconditioning.

- Flat, true and dimensionally accurate
- Smooth stable surface
- Case hardened

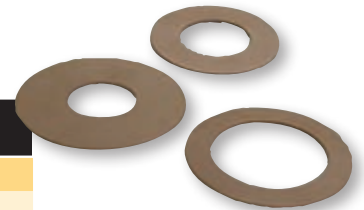

O.D.	I.D.	PART # .015 THICKNESS	PART # .030 THICKNESS	PART # .060 THICKNESS
1.215	.876	03-1050HP-16	03-3050HP-16	03-6050HP-16
1.246	.814	03-1060HP-16	03-3060HP-16	03-6060HP-16
1.300	.520	03-1230HP-16	03-3230HP-16	03-6230HP-16
1.438	.645	03-1135HP-16	03-3135HP-16	03-6135HP-16
1.500	.645	03-1153HP-16	03-3153HP-16	03-6153HP-16
1.634	.643	03-1185SHP-16	03-3185SHP-16	03-6185SHP-16

ROTATOR ELIMINATORS FOR CHEVROLET BIG BLOCK

- Eliminates O.E. spring rotators
- Provides positive spring location
- Flat, true and dimensionally accurate
- Case hardened with a black oxide finish



THICKNESS	O.D.	SPRING O.D.	SPRING I.D.	PART #
.300	1.732	1.568	.623	03-4000-8

PERFORMANCE VALVE STEM SEALS

- Full range of materials for all sealing needs
- Large selection of sizes

AVAILABLE
IN BULK!



STEM DIAMETER	GUIDE DIA.	UNLOADED SEAL DIA.	TYPE	MATERIAL	PART #
5/16"	.476	.575	POSITIVE METAL CLAD	FLUOROVITON	35-8476V-16
5/16"	.485	.625	POSITIVE	FLUOROVITON	35-306V-16
5/16"	.500	.608	POSITIVE METAL CLAD	FLUOROVITON	35-805V-16
5/16"	.502	.625	POSITIVE METAL CLAD	FLUOROVITON	35-804V-16
5/16"	.531	.680	POSITIVE METAL CLAD	FLUOROVITON	35-802V-16
11/32"			O-RING	POLYACRYLIC	35-133P-16
11/32"	.485	.630	POSITIVE METAL CLAD	FLUOROVITON	35-125V-16
11/32"	.500	.610	POSITIVE	TEFLON	35-1611-16
11/32"	.500	.625	POSITIVE	FLUOROVITON	35-104V-16
11/32"	.500	.625	POSITIVE	POLYACRYLIC	35-104P-16
11/32"	.500	.635	POSITIVE METAL CLAD	FLUOROVITON	35-107V-16
11/32"	.531	.630	POSITIVE	TEFLON	35-1711-16
11/32"	.531	.675	POSITIVE METAL CLAD	FLUOROVITON	35-529V-16
11/32"	.531	.680	POSITIVE	POLYACRYLIC	35-408AP-16
11/32"	.552	.678	POSITIVE METAL CLAD	FLUOROVITON	35-371V-16
11/32"	.562	.661	POSITIVE METAL CLAD	FLUOROVITON	35-562V-16
11/32"	.562	.700	POSITIVE	FLUOROVITON	35-305V-16
11/32"	.562	.700	POSITIVE	POLYACRYLIC	35-304P-16
11/32"	.672	.750	UMBRELLA	FLUOROVITON	35-233V-16
11/32"	.672	.750	UMBRELLA	POLYACRYLIC	35-232P-16
3/8"	.500	.600	POSITIVE	TEFLON	35-1612-16
3/8"	.500	.623	POSITIVE METAL CLAD	FLUOROVITON	35-373V-16
3/8"	.531	.630	POSITIVE	TEFLON	35-1712-16
3/8"	.531	.665	POSITIVE METAL CLAD	FLUOROVITON	35-375V-16
3/8"	.562	.675	POSITIVE METAL CLAD	FLUOROVITON	35-377V-16

DIESEL VALVE STEM SEAL SETS

Engine Pro offers the solution to oil control problems in your performance diesel valve seal applications.



APPLICATION	STEM DIA.	GUIDE DIA.	UNLOADED SEAL DIA.	TYPE	PART #
DODGE/CUMMINS 5.9L-6.7L					
6B/6BT (89-98) 12-VALVE	8MM	.552	.668	RING & BAND	35-320V-12
ISB (98-02) 24-VALVE INTAKE	7MM	.484	.539	POSITIVE	35-C59AV-12
ISB (98-02) 24-VALVE EXHAUST	7MM	.484	.636	POSITIVE	35-C59BV-12
ISB (03-15) 24-VALVE	7MM	.484	.640 / 1.122	TOP HAT	35-C59LV-24
FORD/NAVISTAR POWERSTROKE					
6.0L-6.4L (03-10) 32-VALVE	7MM	.440	.615 / 1.000	TOP HAT	35-F60V-32
6.7L (11-16) 32-VALVE	7MM	.470	.690 / .992	TOP HAT	35-F67V-32
6.9L-7.3L IND. INJECT (83-95) 16-VALVE	3/8"	.627	.740	RING & BAND	35-690V-16
7.3L DIRECT INJECT (94-03) 16-VALVE	8MM	.566	.874 / 1.390	TOP HAT	35-F73V-16
GM 6.2L-6.5L V8					
(82-04) 16-VALVE	3/8"	.615	.725	POSITIVE	35-G65V-8
(82-04) 16-VALVE				O-RING	35-133P-16
GM 6.6L DURAMAX					
(01-05) 32-VALVE	7MM	.454	.573	POSITIVE	35-G66V-32
(06-16) 32-VALVE	7MM	.455	.555	POSITIVE	35-G66LV-32

NITRO BLACK MACHINED VALVE LOCKS

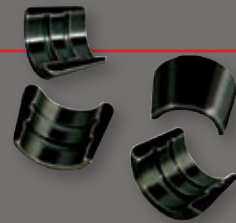

VALVE STEM SIZE	VALVE INSTALLED HEIGHT	LOCK ANGLE	LASH CAP RECESS	PART #
11/32"	STOCK	7 DEGREE	NO	04-1001-32
11/32"	+.050	7 DEGREE	NO	04-1008-32
11/32"	-.050	7 DEGREE	NO	04-1009-32
3/8"	STOCK	7 DEGREE	NO	04-1005-32
3/8"	+.050	7 DEGREE	NO	04-1010-32
3/8"	-.050	7 DEGREE	NO	04-1011-32
8MM	STOCK	7 DEGREE	NO	04-1007-32*
8MM	+.050	7 DEGREE	NO	04-1013-32*
11/32"	STOCK	10 DEGREE	YES	04-1002-32
11/32"	STOCK	10 DEGREE	NO	04-1012-32
11/32"	+.050	10 DEGREE	NO	04-1003-32
11/32"	-.050	10 DEGREE	NO	04-1004-32
3/8"	STOCK	10 DEGREE	YES	04-1006-32

- Precision CNC machined for accuracy
- Consistent valve spring installed height
- High strength 1144 Stress Proof steel alloy
- Recommended for all racing applications
- Available in 7 and 10 degree lock angles
- Made in USA
- Black oxide finish

* Bead lock for Chevrolet LS valves

STAMPED STEEL VALVE LOCKS

PART #

11/32"	STOCK REPLACEMENT 7 DEGREE CASE HARDENED	04-1000-32
--------	--	------------

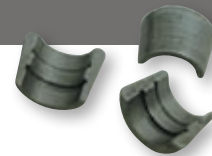

LASH CAPS

- For extreme performance and racing conditions
- CNC machined from hardened 8620 steel
- Finish lapped to insure a parallel plane
- A must when running titanium valves
- EDM oil hole prevents friction welding of cap to valve
- Black oxide finish / made in the USA

VALVE STEM SIZE	OVERALL HT.	THICKNESS	PART #
5/16"	.202	.072	04-1620-16
11/32"	.201	.068	04-1621-16
3/8"	.192	.085	04-1622-16



GUIDE PLATES

Engine Pro Guide Plates are manufactured using high strength steel for maximum rigidity, stability and flex resistance.

IMPORTANT: Using a push rod guide plate will not remedy incorrect valve train geometry.

- Black oxide coating
- Proper positioning promotes valve train stability
- A must for high lift / high spring pressure engine environments

PUSH ROD DIAMETER	TYPE	PART #
CHEVROLET SMALL BLOCK		
5/16"	FLAT	05-1000-8
	STEPPED	05-1001-8
3/8"	FLAT	05-1020-8
	STEPPED	05-1004-8
CHEVROLET BIG BLOCK		
3/8"	STEPPED	05-1002-8
(GEN V & VI WITH 10MM STUD HOLE)	STEPPED	05-1102-8
7/16"	STEPPED	05-1006-8
FORD SMALL BLOCK 289, 302, 351W		
5/16"	FLAT	05-1003-8
3/8"	FLAT	05-1011-8
FORD 302 BOSS, 351C, MODIFIED, 400		
3/8"	STEPPED	05-1012-8
FORD BIG BLOCK 429, 460		
5/16"	STEPPED	05-1015-8
3/8"	STEPPED	05-1014-8



CHROMOLY STEEL ROLLER ROCKER ARMS

- Made from high grade chromoly steel, lighter and three times stronger than aluminum rocker arms
- Trunnion, valve tip roller and shaft made from chromoly material, heat treated to insure long life
- Integral push rod seat
- Design allows clearance for most high performance valve springs
- Extra large trunnions for better load distribution and wear
- Maximum open spring pressure 400 lbs.
- With Engine Pro logo



APPLICATION	STUD DIA.	RATIO	PART #
AMC V8 290-401	7/16"	1.60	07-1118-16 *
CHEVROLET SMALL BLOCK V8	3/8"	1.50	07-1100-16
	7/16"	1.50	07-1101-16
	3/8"	1.60	07-1102-16
	7/16"	1.60	07-1103-16
CHEVROLET BIG BLOCK V8	7/16"	1.72	07-1114-16 *
FORD SMALL BLOCK 260-351W	3/8"	1.60	07-1117-16
	7/16"	1.60	07-1118-16
FORD BOSS 302, 351C-400, 429-460	7/16"	1.72	07-1114-16 *
OLDSMOBILE V8 260-455	3/8"	1.60	07-1117-16 *
PONTIAC V8 265-455	7/16"	1.60	07-1118-16 *^

* Requires screw-in studs, guide plates and hardened pushrods

^ Rocker arm ratio increase over stock 1:5:1; not Ram Air IV

ALUMINUM ROLLER ROCKER ARMS

- Made from aircraft grade 7000 series aluminum
- Trunnion, valve tip roller and shaft made from chromoly material, heat treated to insure long life
- Integral push rod seat design allows clearance for most high performance valve springs
- Extra large trunnions for better load distribution and wear
- Maximum open spring pressure 400 lbs.
- Black anodized finish with Engine Pro logo



APPLICATION	STUD DIA.	RATIO	PART #
AMC V8 290-401	7/16"	1.60	07-1018-16 *
CHEVROLET SMALL BLOCK V8	3/8"	1.50	07-1000-16
	7/16"	1.50	07-1001-16
	3/8"	1.60	07-1002-16
	7/16"	1.60	07-1003-16
CHEVROLET BIG BLOCK V8	7/16"	1.72	07-1014-16 *
FORD SMALL BLOCK 260-351W	3/8"	1.60	07-1017-16
	7/16"	1.60	07-1018-16
FORD BOSS 302, 351C-400, 429-460	7/16"	1.72	07-1014-16 *
OLDSMOBILE V8 260-455	3/8"	1.60	07-1017-16 *
PONTIAC V8 265-455	7/16"	1.60	07-1018-16 *^

* Requires screw-in studs, guide plates and hardened pushrods

^ Rocker arm ratio increase over stock 1:5:1; not Ram Air IV

8740 CHROMOLY ROCKER ARM STUDS

- Forged from 8740 chromoly steel • Induction heat treated and black oxide coated • Rated at 190,000 PSI tensile strength
- Rolled threads and a perfectly flat surface for maximum poly lock engagement



APPLICATION	BASE THREAD DIA.	LENGTH	BASE THREAD DIA.	STUD LENGTH	PART #
CHEVROLET / FORD SMALL BLOCK	7/16"	.680	3/8"	1.750	06-1100-16
	7/16"	.680	7/16"	1.750	06-1101-16
W/ROLLER ROCKERS	7/16"	.710	3/8"	1.895	06-1102-16
CHEVROLET / FORD BIG BLOCK	7/16"	.800	7/16"	1.750	06-1103-16

POLYLOCKS

- 6 point • Alloy steel • Black oxide finish



APPLICATION	STUD DIA	LENGTH	PART #
UNIVERSAL INTAKE AND EXHAUST	3/8"	1.000"	06-4000-16
UNIVERSAL INTAKE AND EXHAUST	7/16"	1.000"	06-4001-16

POLYLOCKS FOR STUD GIRDLES

- 12 point • Alloy steel • Black oxide finish



APPLICATION	STUD DIA	LENGTH	PART #
UNIVERSAL INTAKE AND EXHAUST	3/8"	2.100"	06-4509-8
UNIVERSAL INTAKE AND EXHAUST	7/16"	2.100"	06-4508-8
BB CHEVROLET / FORD EXHAUST	7/16"	2.600"	06-4510-8

Engine Pro LS Chevrolet Bushing Trunnion Kits



- Prevents premature failures caused by the weak O.E. or replacement needle bearings
- Eliminates the possibility of debris from a bearing failure
- Constant oil feed to the bushing surface ensuring proper lubrication
- Greater surface area will support 300 times more load than a needle bearing trunnion

When compared to the bushing in the small end of a connecting rod, our bushing gets more lubrication and has less load, assuring it long service life!

TRUNNION KIT INCLUDES

- Micropolished hardened shafts
- C932 bearing bronze bushings
- C clips



WATCH THE ENGINE PRO LS TRUNNION KIT INSTALLATION VIDEO



INSTALL KIT



APPLICATION	PART #
LS CHEVROLET BUSHING TRUNNION KITS	07-13702-16
TRUNNION INSTALL KIT	LSINST-KIT
LS CHEVROLET BUSHING TRUNNION BOLT KIT*	06-13702-16

*Bolt kit for trunnion kit ordered separately

BOLT KIT



NITRO BLACK PREMIUM SERIES PUSHRODS



Engine Pro's three Premium Series pushrods are available in a range of lengths designed to handle increasing spring pressures and higher RPMs. These thicker wall pushrods are made in the USA from one-piece seamless wall chromoly tubing to give the extra strength required.

FEATURES

- One piece design made from 4130 seamless chromoly tubing
- .210 radius on rocker arm end to avoid pushrod to rocker arm interference
- Carbon nitride treated to 60-62 Rockwell "C" scale hardness
- Sets matched to within +/- .005" overall length
- 5/16 pushrods available in 6.000" to 10.000" lengths in .050 increments.
- 3/8 pushrods available in 7.000" to 11.000" lengths in .050 increments.



MANY MORE SIZES AVAILABLE



HOW TO MEASURE FOR BALL-AND-CUP PUSHRODS

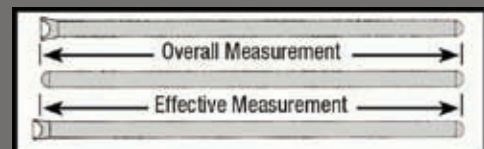

Engine Pro's Pushrod Length Checker Tool is all you'll need. (See pg.18)

5116 SERIES - 5/16" DIAMETER W/.116" WALL CHROMOLY TUBING Added strength for applications with clearance issues

APPLICATION	LENGTH	PART #
CHEVROLET		
LS GEN III & IV STOCK LENGTH	7.400	5116-7400
SMALL BLOCK PLUS .100"	7.900	5116-7900
CHRYSLER		
SMALL BLOCK W/ NON-ADJ. ROCKERS	7.550	5116-7550
BIG BLOCK W/ NON-ADJ. ROCKERS	8.600	5116-8600
FORD		
SMALL BLOCK 289-302	6.800	5116-6800
BIG BLOCK 429-460 72-78 PLUS .050"	8.600	5116-8600

3121S SERIES - 3/8" DIAMETER W/.120" WALL CHROMOLY TUBING

CHEVROLET		
SMALL BLOCK PLUS .100"	7.900	3121S-7900
BIG BLOCK STOCK PLUS .200" (INTAKE)	8.450	3121S-8450
BIG BLOCK STOCK PLUS .200" (EXHAUST)	9.450	3121S-9450
CHRYSLER		
BIG BLOCK W/ NON-ADJ. ROCKERS	8.600	3121S-8600

3141S SERIES - 3/8" DIAMETER W/.140" WALL CHROMOLY TUBING

CHEVROLET		
BIG BLOCK STOCK PLUS .250" (INTAKE)	8.500	3141S-8500
BIG BLOCK STOCK PLUS .250" (EXHAUST)	9.500	3141S-9500
FORD		
BIG BLOCK 429-460 72-78 STOCK LENGTH	8.550	3141S-8550
BIG BLOCK 429-460 72-78 PLUS .050"	8.600	3141S-8600



GO TO THE ENGINE PRO SHOP SOLUTION ON EFFECTIVE LENGTH



4130 PUSHRODS

Engine Pro's premium one-piece pushrod is manufactured from extra thick, premium stainless tube for strength. Made in the USA with exacting attention to the small details that impact the performance of today's high load, high RPM engines.

- 4130 seamless .083 wall chromoly tubing
- Carbon nitride treated to 60-62 rockwell "C" scale
- Ends machined to precise .156 degree radius
- One piece design
- Sets matched within +/- .005 overall length



SEE OUR 4130 PUSHROD VIDEO!

COMPETITION SERIES PUSHRODS

APPLICATION	LENGTH	5/16" DIA. PART #	.040" OIL RESTRICTED #	3/8" DIA. PART #	.040" OIL RESTRICTED #
CHEVROLET LS GEN III & IV					
LESS .050"	7.350	581-7350	581R-7350		
LESS .025"	7.375	581-7375	581R-7375		
STOCK LENGTH	7.400	581-7400	581R-7400		
PLUS .025"	7.425	581-7425	581R-7425		
PLUS .050"	7.450	581-7450	581R-7450		
CHEVROLET SMALL BLOCK					
W/ OEM ROLLER CAM	7.200	581-7200	581R-7200	381-7200	381R-7200
STOCK LENGTH	7.800	581-7800	581R-7800	381-7800	381R-7800
LESS .100"	7.700	581-7700	581R-7700	381-7700	381R-7700
LESS .050"	7.750	581-7750	581R-7750	381-7750	381R-7750
PLUS .050"	7.850	581-7850	581R-7850	381-7850	381R-7850
PLUS .100"	7.900	581-7900	581R-7900	381-7900	381R-7900
PLUS .150"	7.950	581-7950	581R-7950	381-7950	381R-7950
PLUS .200"	8.000	581-8000	581R-8000	381-8000	381R-8000
CHEVROLET BIG BLOCK					
STOCK LENGTH (INTAKE)	8.250			381-8250	381R-8250
STOCK LENGTH (EXHAUST)	9.250			381-9250	381R-9250
PLUS .100" (INTAKE)	8.350			381-8350	381R-8350
PLUS .100" (EXHAUST)	9.350			381-9350	381R-9350
W/ TALL DECK (INTAKE)	8.650			381-8650	381R-8650
W/ TALL DECK (EXHAUST)	9.650			381-9650	381R-9650
CHRYSLER					
SMALL BLOCK W/ NON-ADJ. ROCKERS	7.500	581-7500	581R-7500		
SMALL BLOCK W/ NON-ADJ. ROCKERS PLUS .050"	7.550	581-7550	581R-7550		
BIG BLOCK W/ NON-ADJ. ROCKERS	8.600	581-8600	581R-8600	381-8600	381R-8600
FORD					
64-69 289-302	6.800	581-6800	581R-6800		
69-78 351W	8.150	581-8150	581R-8150		
69-71 429-460 STOCK LENGTH	8.700	581-8700	581R-8700	381-8700	381R-8700
72-78 429-460 STOCK	8.550	581-8550	581R-8550	381-8550	381R-8550
72-78 429-460 STOCK PLUS .050"	8.600	581-8600	581R-8600	381-8600	381R-8600
OLDSMOBILE					
71-79 400-455 STOCK	9.750	581-9750	581R-9750	381-9750	381R-9750
PONTIAC					
61-67 326-389 STOCK	8.700	581-8700	581R-8700	381-8700	381R-8700
67-79 350-455 STOCK	9.150	581-9150	581R-9150	381-9150	381R-9150

1010 PUSHRODS

Engine Pro's premium 1010 steel pushrods are made for use in street and mild race applications with under 400 lbs open seat pressure.

5/16" DIAMETER 1010 SERIES PUSHRODS

APPLICATION	LENGTH	PART #
CHEVROLET LS GEN III & IV		
W/OEM ROLLER CAM STOCK LENGTH	7.400	16-1020-16
CHEVROLET SMALL BLOCK		
W/OEM ROLLER CAM STOCK LENGTH	7.200	16-1007-16
W/RETRO-ROLLER CAM	7.300	16-1009-16
W/FLAT TAPPET CAM STOCK LENGTH	7.800	16-1000-16
LESS .050" W/FLAT TAPPET CAM	7.750	16-1004-16
LESS .100" W/FLAT TAPPET CAM	7.700	16-1005-16
LESS .150" W/FLAT TAPPET CAM	7.650	16-1006-16
PLUS .050" W/FLAT TAPPET CAM	7.850	16-1008-16
PLUS .100" W/FLAT TAPPET CAM	7.900	16-1001-16
PLUS .150" W/FLAT TAPPET CAM	7.950	16-1002-16
PLUS .200" W/FLAT TAPPET CAM	8.000	16-1003-16

- .094" wall tubing
- Hardened for use with guide plates
- O.D. finish ground
- 58 'C' scale rockwell hardness
- Swedged ends and 1-piece construction
- Black oxide finish



DIESEL PERFORMANCE PUSHRODS

- Made from 4130 seamless chromoly tubing
- Manufactured extra thick for added strength
- Carbon nitride treated to 60-62 Rockwell "C" scale hardness

APPLICATION	EFFECTIVE LENGTH	QUANTITY	PART #
3/8" DIAMETER W/.083" WALL. ALSO AVAILABLE IN .121" AND .145" WALL THICKNESS. AVAILABLE IN CUSTOM LENGTHS.			
CUMMINS			
5.9L 12-VALVE 1989-98	10.700	12	NH38A-EB-10.700
5.9L 24-VALVE 1998-09	11.232	12	NH38A-56-11.232
3/8" DIAMETER W/.083" WALL. ALSO AVAILABLE IN .121" AND .145" WALL THICKNESS. AVAILABLE IN CUSTOM LENGTHS.			
FORD			
6.0L 32-VALVE 2003-09	9.850	16	NH5116B-DD-9.850
6.4L 32-VALVE 2008-10	9.800	16	NH5116B-DD-9.800
6.7L 32-VALVE 2011-16	9.398	32	NH5116B-DQ-9.398
3/8" DIAMETER W/.083" WALL. ALSO AVAILABLE IN .121" AND .145" WALL THICKNESS AND CUSTOM LENGTHS.			
FORD			
7.3L 16-VALVE 1994-03	10.250	16	NH38B-DD-10.250
GENERAL MOTORS			
6.6L 32-VALVE 2001-16	9.219	16	NH38B-3N-9.219

PUSHROD LENGTH CHECKER KIT

Correct valve train geometry is a must to obtain desired results from the camshaft and to avoid damage to the rest of the valve train. Our Pushrod Length Checker Kit makes it easy to determine the proper pushrod length.

DESCRIPTION	PART #
SET OF 12 TUBES IN 1/2" INCREMENTS FROM 6" TO 12"	LC5A-K

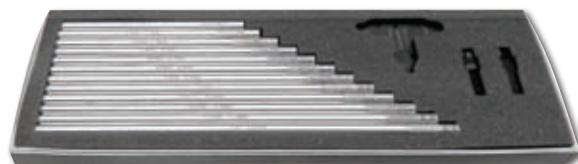

HIGH RPM SERIES HYDRAULIC ROLLER LIFTERS



- Made from a billet body and have a clipped axle
- **7000+ RPM capability** with .120" plunger travel
- **Internal tolerances are much tighter in this series**
- Recommended spring pressure: 100-225lbs seat pressure; 350-550lbs open pressure

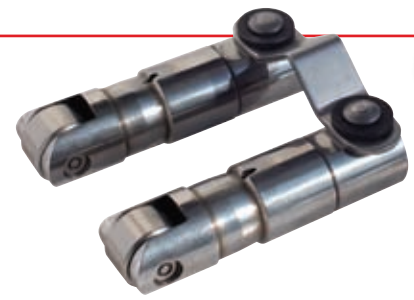

APPLICATION		BODY DIA.	ROLLER DIA.	PART #
CHEVROLET	SMALL BLOCK PRESSURIZED OILING	.842	.750	17-5044-16
	SMALL BLOCK HIGH RPM	.875	.750	17-7687-16
	SMALL BLOCK PRESSURIZED OILING	.903	.810	17-5468-16
	LS - FITS 5 & 6 HEAD BOLT PATTERN	.842	.750	17-5294-16
	LS LIMITED TRAVEL - FITS 5 & 6 HEAD BOLT PATTERN	.842	.750	17-7260-16
	LS PRESSURIZED OILING, 5 & 6 HEAD BOLT PATTERN	.903	.810	17-5472-16
	LS LIMITED TRAVEL, STD BORE SPACING	.903	.810	17-7692-16
	BIG BLOCK	.842	.750	17-5045-16
	BIG BLOCK LIMITED TRAVEL	.842	.750	17-7530-16
	BIG BLOCK PRESSURIZED OILING	.903	.810	17-5470-16
CHRYSLER	SMALL BLOCK EARLY-A & MAGNUM BLOCKS	.903	.810	17-6072-16
	BIG BLOCK B & RB	.903	.810	17-6074-16
FORD	SMALL BLOCK, WINDSOR & 351C-400	.903	.810	17-6083-16
	BIG BLOCK 429-460 & FE SERIES	.903	.810	17-6085-16
PONTIAC	389-400-421-428-455 MAY REQUIRE BLOCK BUSHINGS	.842	.750	17-6451-16

PRO SERIES HYDRAULIC ROLLER LIFTERS

- Made from a billet body with a clipped axle and have 7000 RPM capability
- .120" plunger travel and have an 80% fill rate with the test oil
- Machined from tool steel and centerless ground to .0003 tolerance
- **Limited travel-** Intended for use in stock racing classes where some plunger travel is required. .015"-.030" plunger travel before going solid. Some valve train noise can be associated with these lifters
- Recommended spring pressure: 100-250lbs seat pressure; 285-650lbs open pressure



APPLICATION		BODY DIA.	ROLLER DIA.	PART #
CHEVROLET	SMALL BLOCK	.842	.750	17-4602-16
	SMALL BLOCK LIMITED TRAVEL	.842	.750	17-4789-16
	LS-FITS 5 & 6 BOLT HEAD PATTERN	.842	.750	17-5206-16
	LS-LIMITED TRAVEL, FITS 5 & 6 BOLT HEAD PATTERN	.842	.750	17-5850-16
	BIG BLOCK	.842	.750	17-4603-16
	BIG BLOCK LIMITED TRAVEL	.842	.750	17-4795-16
	348-409	.842	.750	17-6087-16
CHRYSLER	SB EARLY-A & MAGNUM LIMITED TRAVEL	.903	.810	17-7358-16
	BIG BLOCK-B & RB LIMITED TRAVEL	.903	.810	17-7360-16
FORD	SMALL BLOCK, WINDSOR & 351C-400	.875	.750	17-5879-16
	SB, WINDSOR & 351C-400 LIMITED TRAVEL	.875	.750	17-7262-16
	BIG BLOCK 429-460 & FE	.875	.750	17-5891-16
PONTIAC	400-421-428-455 OEM OIL BAND , BLOCK BUSHING SUGGESTED	.842	.750	17-6398-16
OEM STYLE PERFORMANCE HYDRAULIC ROLLER LIFTERS		BODY DIA.	ROLLER DIA.	PART #
CHEVROLET	LS-FITS STOCK LIFTER GUIDES	.842	.750	17-4708-16
	LS- LIMITED TRAVEL, FITS STOCK LIFTER GUIDES	.842	.750	17-4793-16

Important, use an oil that has a centistoke rating of below 11 at 100c when using this series of lifters

STREET PERFORMANCE HYDRAULIC ROLLER LIFTERS

- Made from a cold formed body with a clipped axle and have a 6500 RPM capability
- Updates vintage engines to a modern hydraulic roller lifter • .120" plunger travel
- .700" diameter lifter wheel for cam designs up to .370" lobe lift
- Recommended spring pressure: 100-180 lbs seat pressure; 280-380 lbs open pressure



APPLICATION		BODY DIA.	ROLLER DIA.	PART #
AMC	304-401	.903	.700	17-6076-16
BUICK	350	.842	.700	17-5386-16
	401-425-455	.842	.700	17-5333-16
	TURBO V6	.842	.700	17-5393-12
	TURBO V6 LIMITED TRAVEL	.842	.700	17-6402-12
CADILLAC	425-472-500	.842	.700	17-5331-16
CHEVROLET	SMALL BLOCK	.842	.700	17-5372-16
		.875	.700	17-7565-16
	LS	.842	.700	17-5290-16
	BIG BLOCK	.842	.700	17-5374-16
		.875	.700	17-6917-16
	348-409	.842	.700	17-5339-16
CHRYSLER	SMALL BLOCK EARLY-A & MAGNUM	.903	.700	17-5321-16
	BIG BLOCK-B & RB	.903	.700	17-5319-16
	VIPER V-10	.842	.700	17-6438-20
FORD	SMALL BLOCK, WINDSOR & 351C-400	.875	.700	17-5323-16
	SB, WINDSOR & 351C-400 LIMITED TRAVEL	.875	.700	17-5327-16
	BIG BLOCK 429-460 & FE	.875	.700	17-5325-16
	BIG BLOCK 429-460 & FE LIMITED TRAVEL	.875	.700	17-5329-16
HOLDEN	V8	.842	.700	17-5337-16
OLDSMOBILE	400-403-425-455 MAY NEED TO CLEARANCE OEM INTAKE MANIFOLD	.842	.700	17-5335-16
PONTIAC	389-400-421-428-455 OIL BAND IN OEM LOCATION	.842	.700	17-5884-16

OEM STREET PERFORMANCE HYDRAULIC ROLLER LIFTERS

- .120" plunger travel and have an 80% fill rate
- .700" diameter lifter wheel for cam designs up to .370" lobe lift
- Recommended spring pressure: 100-180 lbs seat pressure; 280-380 lbs open pressure



APPLICATION		BODY DIA.	ROLLER DIA.	PART #
CHEVROLET	SMALL BLOCK-POLISHED BODY, LOCK RING AXLE	.842	.700	17-5315-16
	LS-POLISHED BODY, LOCK RING AXLE, FITS STOCK LIFTER GUIDE, RECOMMENDED MAX CAM LIFT .360" MIN. BC 1.445"	.842	.700	17-7717-16

OEM CHEVROLET LS ROLLER LIFTER GUIDE KIT

- Includes 4 lifter buckets and 4 mounting screws

APPLICATION	PART #
GEN III & IV NON-AFM STOCK GUIDES	17-9365K



IMPORTANT: FOR HYDRAULIC LIFTERS TO FUNCTION CORRECTLY YOU MUST USE AN OIL WITH A CENTISTOKE RATING BELOW 15 AT 100C. IF NOT THE LIFTER MAY NOT FUNCTION CORRECTLY

NOTE: All lifters with a tie bar are designed to be installed in either Retro-Fit engines or engines originally equipped with roller lifters

ENGINE PRO NITRO BLACK ROLLER LIFTERS

TIE BAR AND KEYED MECHANICAL ROLLER LIFTERS



REVOLUTIONARY OIL WEDGE DESIGN

- Billet body with pinned axle and 9000 + RPM capability
- Special B624L matrix material axle that is .470" diameter with FULL TIME PRESSURIZED OILING
- Diamond-Like Coating (DLC) for less friction, wear and durability
- These lifters have the carrying capacity of a 1" lifter!
- Special break-in lube between the axle and roller wheel should not be washed with solvent prior to installation
- Requires a break-in period of 25-30 minutes varying the RPM from 1800-2200 RPM
- Recommended spring pressure: 150-400lbs seat pressure; 550-1000lbs open pressure
- These lifters are rebuildable and are made in the U.S.A.

DESCRIPTION	BODY DIA.	ROLLER DIA.	PART #
CHEVROLET SMALL BLOCK			
ON CENTER (ALSO FOR SB2 HEADS ON STD BLOCK)	.842	.750	17-6475-16
.180 L&R INT OFFSET	.842	.750	17-6478-16
.180 L&R INT & EX OFFSET	.842	.750	17-6480-16
SBC/BUICK .180 L INT OFFSET	.842	.750	17-6481-16
ON CENTER	.903	.810	17-6651-16
.180 INT & EX OFFSET	.903	.810	17-6656-16
.180 L&R INT OFFSET	.903	.810	17-6654-16
SBC/BUICK .180 L INT OFFSET	.903	.810	17-6657-16
KEYED, ON CENTER	.936	.850	17-6563-16
KEYED, 8- EX ON CENTER, 8- .180 L INT OFFSET	.936	.850	17-6564-16
CHEVROLET LS WITH 5 & 6 HEAD BOLT PATTERN			
ON CENTER	.842	.750	17-6483-16
.180 L INT OFFSET	.842	.750	17-6485-16
.180 L INT & EX OFFSET	.842	.750	17-6487-16
ON CENTER	.903	.810	17-6659-16
.180 L INT OFFSET	.903	.810	17-6661-16
10 DEGREE DART HEAD .180 R INT OFFSET	.903	.810	17-7391-16
KEYED, ON CENTER	.936	.850	17-6565-16
KEYED, 8- EX ON CENTER, 8- .180 L INT OFFSET	.936	.850	17-6566-16

Continued on next page

ENGINE PRO NITRO BLACK ROLLER LIFTERS CONTINUED

TIE BAR AND KEYED MECHANICAL ROLLER LIFTERS

DESCRIPTION	BODY DIA.	ROLLER DIA.	PART #
CHEVROLET BIG BLOCK			
ON CENTER	.842	.750	17-6489-16
U/P P/O +.300 (.180 L&R INT O/S)	.842	.750	17-6492-16
.150 INT & EX OFFSET	.842	.750	17-6494-16
ON CENTER	.903	.810	17-6663-16
.180 R INT OFFSET	.903	.810	17-6667-16
.180 INT & EX OFFSET	.903	.810	17-6669-16
.180 L&R INT OFFSET	.903	.810	17-6666-16
8- EX ON CENTER, 8- .180 L&R INT OFFSET	.936	.850	17-6580-16
KEYED, ON CENTER	.936	.850	17-6568-16
CHEVROLET 348-409 CU. IN.			
ON CENTER	.842	.750	17-6496-16
CHRYSLER SMALL BLOCK			
ON CENTER	.903	.810	17-6683-16
CHRYSLER BIG BLOCK			
ON CENTER	.903	.810	17-6685-16
.180 L&R INT OFFSET	.903	.810	17-6688-16
CHRYSLER VIPER V10			
.180 INT & EX OFFSET	.842	.750	17-6633-20
FORD SMALL BLOCK			
ON CENTER	.903	.810	17-6673-16
.180 R INT OFFSET	.903	.810	17-6675-16
.180 INT & EX OFFSET	.903	.810	17-6677-16
KEYED, ON CENTER	.936	.850	17-6582-16
KEYED, 8- EX ON CENTER, 8- .180 R INT OFFSET	.936	.850	17-6584-16
FORD BIG BLOCK 429-460			
ON CENTER	.903	.810	17-6679-16
.180 R INT OFFSET	.903	.810	17-6681-16
PONTIAC 400-421-428-455 CU. IN.			
ON CENTER	.842	.750	17-6498-16
ON CENTER, +.150 L & R INT OFFSET	.842	.750	17-7149-16
ON CENTER	.903	.810	17-6671-16

NOTE: All lifters with a tie bar are designed to be installed in either Retro-Fit engines or engines originally equipped with roller lifters.



ENDURANCE SERIES MECHANICAL ROLLER LIFTERS



The NEW Engine Pro Endurance Series mechanical roller lifters have many of the same features as our **Nitro Black Series**.

- Made from a billet body with a pinned axle and have 9000 + RPM capability
- Axle diameter is .470" with full time pressurized oiling
- Highly polished body for less friction and wear durability
- Special break-in lube between the axle and roller wheel should not be washed with solvent prior to installation
- Requires a break-in period of 25-30 minutes varying the RPM from 1800-2200 RPM
- Recommended spring pressure; 150- 400lbs seat pressure; 550-1000lbs open pressure



APPLICATION		DESCRIPTION	BODY DIA.	ROLLER DIA.	PART #
CHEVROLET	SMALL BLOCK	ON CENTER	.842	.750	17-6690-16
		.150 L&R INT OFFSET	.842	.750	17-6693-16
		.150 INT & EX OFFSET	.842	.750	17-6695-16
		.150 L INT OFFSET	.842	.750	17-6697-16
		ON CENTER	.903	.810	17-6708-16
		.180 L&R INT OFFSET	.903	.810	17-6711-16
		.180 INT & EX OFFSET	.903	.810	17-6713-16
	SMALL BLOCK CHEV/BUICK	.180 L INT OFFSET	.903	.810	17-6715-16
	LS	ON CENTER	.842	.750	17-6717-16
		.150 L INT OFFSET	.842	.750	17-6719-16
		.150 INT & EX OFFSET	.842	.750	17-6721-16
		.180 L INT OFFSET	.903	.810	17-6725-16
		ON CENTER	.903	.810	17-6723-16
	BIG BLOCK	ON CENTER	.842	.750	17-6727-16
		.150 L&R INT OFFSET	.842	.750	17-6730-16
		.150 INT & EX OFFSET	.842	.750	17-6732-16
		ON CENTER	.903	.810	17-6734-16
		.180 L&R INT OFFSET	.903	.810	17-6737-16
		.180 R INT OFFSET	.903	.810	17-6738-16
		.180 INT & EX OFFSET	.903	.810	17-6740-16
	348-409	ON CENTER	.842	.750	17-6742-16
CHRYSLER	SMALL BLOCK A	ON CENTER	.903	.810	17-6774-16
	BIG BLOCK B & RB	ON CENTER	.903	.810	17-6776-16
		.180 L&R INT OFFSET	.903	.810	17-6779-16
FORD	SMALL BLOCK	ON CENTER	.903	.810	17-6756-16
		.180 R INT OFFSET	.903	.810	17-6758-16
		.180 INT & EX OFFSET	.903	.810	17-6760-16
		ON CENTER	.903	.810	17-6770-16
	BIG BLOCK 429-460	.180 R INT OFFSET	.903	.810	17-6772-16
PONTIAC	400-421-428-455	ON CENTER	.842	.750	17-6746-16
		ON CENTER	.903	.810	17-6744-16
		.180 L&R INT OFFSET	.903	.810	17-7681-16

NOTE: All lifters with a tie bar are designed to be installed in either Retro-Fit engines or engines originally equipped with roller lifters.

ULTRA BUSHING SERIES MECHANICAL ROLLER LIFTERS

- Made from a billet body with a clipped axle and have **8000 + RPM capability**
- Special break-in lube between the axle and roller wheel should not be washed with solvent prior to installation
- Requires a break-in period of 25-30 minutes varying the RPM from 1800-2200 RPM
- **PRESSURIZED OILING TO THE ROLLERS**
- Recommended spring pressure: 250-350lbs seat pressure; 600-850lbs open pressure



APPLICATION		DESCRIPTION	BODY DIA.	ROLLER DIA.	PART #	
CHEVROLET	SMALL BLOCK	.180 L&R INT OFFSET	.842	.750	17-6114-16	
		.180 INT & EX OFFSET	.842	.750	17-6348-16	
		ON CENTER	.875	.750	17-6116-16	
		.180 L&R INT OFFSET	.875	.750	17-6551-16	
		ON CENTER	.903	.810	17-6118-16	
		.180 L&R INT OFFSET	.903	.810	17-6121-16	
		.180 INT & EX OFFSET	.903	.810	17-6359-16	
		ON CENTER	.936	.850	17-6125-16	
		.180 L&R INT OFFSET	.936	.850	17-6128-16	
		SMALL BLOCK CHEV/BUICK	.180 LEFT INT OFFSET	.903	.810	17-6123-16
	LS	ON CENTER	.842	.750	17-6177-16	
		ON CENTER	.903	.810	17-6132-16	
		.180 LEFT INT OFFSET	.903	.810	17-6136-16	
		KEYED BUSHINGS REQUIRED	.936	.850	17-5564-16	
		BIG BLOCK	.180 L&R INT OFFSET	.842	.750	17-6141-16
			ON CENTER	.903	.810	17-6143-16
	.180 L&R INT OFFSET		.903	.810	17-6146-16	
	.180 RH INT OFFSET		.903	.810	17-6148-16	
	.180 INT & EXH OFFSET		.903	.810	17-6363-16	
	ON CENTER		.936	.850	17-6202-16	
CHRYSLER	SMALL BLOCK A	.180 L&R INT OFFSET	.936	.850	17-6204-16	
		ON CENTER	.903	.810	17-5260-16	
		ON CENTER	.903	.810	17-6170-16	
	BIG BLOCK B & RB	.180 L & R INT OFFSET	.903	.810	17-6535-16	
		ON CENTER	.903	.810	17-5270-16	
		ON CENTER	.903	.810	17-6172-16	
		.180 L&R INT OFFSET	.903	.810	17-6175-16	
		.180 INT & EX OFFSET	.903	.810	17-7441-16	
		ON CENTER	.936	.850	17-6506-16	
		.180 L&R INT OFFSET	.936	.850	17-6578-16	
VIPER V10	ON CENTER	.842	.750	17-6434-20		
	ON CENTER	.903	.810	17-6436-20		

NOTE: All lifters with a tie bar are designed to be installed in either Retro-Fit engines or engines originally equipped with roller lifters



ENGINEPROSHOPSOLUTIONS.COM

NUMBER YOUR LIFTERS

When installing flat tappet lifters, we number the lifters to their corresponding cylinders. This can be useful in the event that the engine is ever disassembled. This helps to keep the lifters from getting out of order and to ensure they are put back on the correct lobe to help prevent the camshaft lobes from going flat.

Adam Cofer Salina Engine Salina, KS September, 2020



MORE ENGINE PRO SHOP SOLUTIONS

ULTRA BUSHING SERIES MECHANICAL ROLLER LIFTERS CONTINUED



APPLICATION		DESCRIPTION	BODY DIA.	ROLLER DIA.	PART #	
FORD	SMALL BLOCK, 289-351W	ON CENTER	.875	.750	17-6152-16	
		.180 RIGHT INT OFFSET	.875	.750	17-6156-16	
		.180 INT & EX OFFSET	.875	.750	17-6243-16	
		ON CENTER	.903	.810	17-6158-16	
		.180 R INT OFFSET	.903	.810	17-6160-16	
		.180 INT & EX OFFSET	.903	.810	17-6396-16	
		ON CENTER	.936	.850	17-6365-16	
		.180 RIGHT INT OFFSET	.936	.850	17-6415-16	
		.180 INT & EX OFFSET	.936	.850	17-7142-16	
		CLEVELAND 351C-400	ON CENTER	.875	.750	17-6154-16
		BIG BLOCK 429-460	ON CENTER	.875	.750	17-6162-16
			ON CENTER	.903	.810	17-6166-16
			.180 R INT OFFSET	.903	.810	17-6168-16
		352-390-410-428 FE	ON CENTER	.875	.750	17-6164-16
			.180 INT & EX OFFSET	.875	.750	17-6530-16
			.180 INT & EX OFFSET	.936	.850	17-6532-16
	PONTIAC	400-421-428-455	ON CENTER	.903	.810	17-6392-16
.180 L&R INT OFFSET			.903	.810	17-6400-16	

NOTE: All lifters with a tie bar are designed to be installed in either Retro-Fit engines or engines originally equipped with roller lifters

ULTRA SERIES MECHANICAL ROLLER LIFTERS

- Made from a billet body with a clipped axle and have 8000 + RPM capability
- PRESSURIZED OILING TO THE ROLLERS
- Recommended spring pressure: 250-350 lbs seat Pressure; 600-850 lbs open pressure



APPLICATION		DESCRIPTION	BODY DIA.	ROLLER DIA.	PART #	
AMC	290-401	ON CENTER	.903	.810	17-7689-16	
		ON CENTER	.842	.750	17-7532-16	
CHEVROLET	SMALL BLOCK	ON CENTER	.842	.750	17-4843-16	
		.180 L&R INT OFFSET	.842	.750	17-4838-16	
		.180 INT & EX OFFSET	.842	.750	17-6190-16	
			ON CENTER	.875	.750	17-5919-16
			.180 L&R INT OFFSET	.875	.750	17-5910-16
			.180 INT & EX OFFSET +.200	.875	.750	17-7708-16
			ON CENTER	.903	.810	17-4867-16
			.180 L&R INT OFFSET	.903	.810	17-4872-16
			.180 INT & EX OFFSET	.903	.810	17-6192-16
			ON CENTER	.936	.850	17-4877-16
			.180 L&R INT OFFSET	.936	.850	17-4882-16
			.180 INT & EX OFFSET	.936	.850	17-7563-16
		SMALL BLOCK CHEV/BUICK	.180 LEFT INT OFFSET	.842	.750	17-4914-16
	.180 LEFT INT OFFSET		.903	.810	17-4989-16	

NOTE: All lifters with a tie bar are designed to be installed in either Retro-Fit engines or engines originally equipped with roller lifters

ULTRA SERIES MECHANICAL ROLLER LIFTERS CONTINUED



SUBSCRIBE TO ENGINE PRO'S VIDEO CHANNEL

APPLICATION		DESCRIPTION	BODY DIA.	ROLLER DIA.	PART #
CHEVROLET	LS	ON CENTER	.842	.750	17-5425-16
		ON CENTER	.903	.810	17-5428-16
		.180 LEFT INT OFFSET	.903	.810	17-5457-16
	BIG BLOCK	.180 INT & EX OFFSET	.903	.810	17-6356-16
		ON CENTER	.842	.750	17-4845-16
		ON CENTER W/NASCAR BEARING AXLE	.842	.750	17-6039-16
		.180 L&R INT OFFSET	.842	.750	17-4841-16
		.180 L&R INT OFFSET W/NASCAR BEARING AXLE	.842	.750	17-6042-16
		ON CENTER	.875	.750	17-6574-16
		.180 L&R INT OFFSET	.875	.750	17-7281-16
		ON CENTER	.903	.810	17-4869-16
		.180 L&R INT OFFSET	.903	.810	17-4875-16
		.180 RH INT OFFSET	.903	.810	17-6048-16
		.180 INT & EX OFFSET	.903	.810	17-6361-16
		ON CENTER	.936	.850	17-4879-16
.180 L&R INT OFFSET	.936	.850	17-4885-16		
CHRYSLER	BIG BLOCK B & RB	.180 L&R INT OFFSET	.903	.810	17-5561-16
		ON CENTER .200 BORE SPACING	.903	.810	17-7309-16
FORD	SMALL BLOCK, 289-351W	ON CENTER	.875	.750	17-5436-16
		.180 RH INT OFFSET	.875	.750	17-5557-16
		.180 INT & EX OFFSET	.875	.750	17-7146-16
		ON CENTER	.903	.810	17-5490-16
		.180 RH INT OFFSET	.903	.810	17-5488-16
		.180 RH INT OFFSET	.936	.850	17-7551-16
	CLEVELAND 351C-400	ON CENTER	.875	.750	17-5440-16
	BIG BLOCK 429-460	ON CENTER	.875	.750	17-5456-16
		.180 INT & EX OFFSET	.875	.750	17-7534-16
		ON CENTER	.903	.810	17-5505-16
	352-390-410-428 FE	.180 RH INT OFFSET	.903	.810	17-5506-16
ON CENTER		.875	.750	17-5454-16	
ON CENTER		.903	.810	17-7555-16	
PONTIAC	400-421-428-455	ON CENTER	.842	.750	17-7481-16

NOTE: All lifters with a tie bar are designed to be installed in either Retro-Fit engines or engines originally equipped with roller lifters

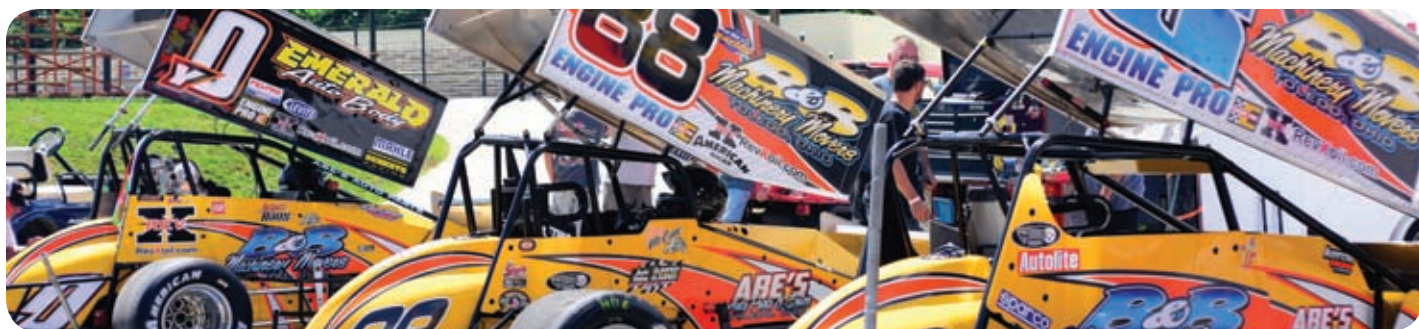

NASCAR SERIES MECHANICAL ROLLER LIFTERS

- Durable Solid Lubricant (DSL) Coating
- PRESSURIZED OILING TO THE ROLLERS
- NASCAR keyed roller lifters



APPLICATION		DESCRIPTION	BODY DIA.	ROLLER DIA.	PART #
CHEVROLET	SMALL BLOCK RO-7	REMOVABLE SEAT	.936	.850	17-6182-16
		FULL TIME BEARING OILING FIXED SEAT	.936	.850	17-5006-16
		FULL TIME BEARING OILING DLC COATING	.936	.850	17-6637-16
FORD	SMALL BLOCK	FULL TIME BEARING OILING	.903	.810	17-5228-16
CHRYSLER	SMALL BLOCK	FULL TIME BEARING OILING	.936	.850	17-4969-16
TOYOTA	NASCAR ENGINE		.936	.850	17-4970-16



TOP DRAG SERIES MECHANICAL ROLLER LIFTERS

Specialty Chrysler applications.

APPLICATION	DESCRIPTION	BODY DIA.	ROLLER DIA.	PART #
TOP ALCOHOL	TIE BAR 2.000 BORE SPACE	0.903	.810	17-5446-16
	TIE BAR STOCK 1.800 BORE SPACE (NO PUSHROD OILING)	0.903	.810	17-6647-16
TOP FUEL	SINGLE ROLLER BOTH SIDES (NO PUSHROD OILING)	1.000	.920	17-4849-16
	SINGLE ROLLER BOTH SIDES (NO PUSHROD OILING)	1.063	.000	17-4552-16



SPORTSMAN PRO SERIES MECHANICAL ROLLER LIFTERS

- Made from a billet body with a clipped axle and have **7500 RPM capability**
- .750" diameter roller wheel
- **PRESSURIZED OILING TO THE ROLLERS**
- Machined to work with **REDUCED BASE CIRCLE** camshafts

- Bodies are fully polished for reduced friction
- Recommended spring pressure 150-275 lbs seat pressure 400-700 lbs open pressure



APPLICATION		BODY DIA.	ROLLER DIA.	PART #
CHEVROLET	SMALL BLOCK	.842	.750	17-6591-16
	BIG BLOCK	.842	.750	17-6593-16
FORD	WINDSOR SMALL BLOCK, 289-351W	.875	.750	17-7699-16
	CLEVELAND 351-400	.875	.750	17-7701-16
	BIG BLOCK 429-460	.875	.750	17-7703-16
	FE 352-390-410-428	.875	.750	17-7705-16

SPORTSMAN SERIES MECHANICAL ROLLER LIFTERS

- Made from a billet body with a clipped axle and have **7500 RPM capability**
- .750" diameter roller wheel

- Recommended spring pressure 150-275 lbs seat pressure 400-700 lbs open pressure



APPLICATION		BODY DIA.	ROLLER DIA.	PART #
CHEVROLET	SMALL BLOCK .300 TALL ON CENTER	.842	.750	17-4604-16
	LS FITS STOCK LIFTER GUIDES (NOT TIE BAR)	.842	.750	17-4737-16
	LS .842D T/B MECH ROLLER FOR STD & HI LIFT	.842	.750	17-5452-16
	BIG BLOCK .300 TALL ON CENTER	.842	.750	17-4606-16
CHRYSLER	SMALL BLOCK EARLY-A & MAGNUM BLOCKS	.903	.750	17-4723-16
	BIG BLOCK B & RB	.903	.750	17-4730-16
FORD	WINDSOR SMALL BLOCK, 289-351W	.875	.750	17-4713-16
	CLEVELAND 351-400	.875	.750	17-5411-16
	BIG BLOCK 429-460	.875	.750	17-4719-16
	FE 352-390-410-428	.875	.750	17-4726-16

HORIZONTAL TIE BAR MECHANICAL ROLLER LIFTERS

- Made from a billet body with a clipped axle and have **7000 RPM capability**
- Limited to lobe lifts of no more than .375"
- They have a .750" diameter roller wheel
- Recommended spring pressure: 150-275 lbs seat pressure; 400-700 lbs open pressure



APPLICATION		BODY DIA.	ROLLER DIA.	PART #
CHEVROLET	SMALL BLOCK	.842	.750	17-4601-16
	BIG BLOCK	.842	.750	17-4677-16

NOTE: All lifters with a tie bar are designed to be installed in either Retro-Fit engines or engines originally equipped with roller lifters



STREET PERFORMANCE MECHANICAL ROLLER LIFTERS

- Made from a cold formed body with a clipped axle and have 7000 RPM capability
- .700" diameter roller wheel
- Recommended spring pressure 150-220 lbs
seat pressure 300-550 lbs open pressure



APPLICATION		BODY DIA.	ROLLER DIA.	PART #
BUICK	350	.842	.700	17-5555-16
	401-425-455 CU IN V-8	.842	.700	17-5345-16
	TURBO V6	.842	.700	17-5553-12
CADILLAC	425-472-500 CU IN V-8	.842	.700	17-5356-16
CHEVROLET	SMALL BLOCK	.842	.700	17-5511-16
	LS FITS STOCK LIFTER GUIDES (NOT TIE BAR)	.842	.700	17-6528-16
	LS	.842	.700	17-5989-16
	BIG BLOCK	.842	.700	17-5547-16
	348 409 .842D T/B STREET PERF MECH ROLLER	.842	.700	17-5347-16
FORD	SMALL BLOCK, WINDSOR & 351C-400	.875	.700	17-5517-16
	BIG BLOCK 429-460 & FE	.875	.700	17-5520-16
HOLDEN	V8	.842	.700	17-5343-16

EDM SOLID FLAT TAPPET LIFTERS

- **Solid flat tappets** are hand selected castings that meet OEM specs
- High RMS finish on the lifter to ensure proper bore to body clearance in the engine
- EDM drilled with a .024" hole for direct oil feed to the cam lobe to prevent premature cam wear



FLAT TAPPET PERFORMANCE MECHANICAL LIFTERS WITH EDM HOLE

APPLICATION	BODY DIA.	PART #
CHEVROLET, OLDS, PONTIAC, CADILLAC	.842	17-5035-16

NOTE: All lifters with a tie bar are designed to be installed in either Retro-Fit engines or engines originally equipped with roller lifters



ENGINE PRO DIESEL PERFORMANCE CAMSHAFTS

For Ford Powerstroke, GM Duramax and Dodge Cummins Engines



Our Camshafts Deliver More Horsepower, More Torque and Better Fuel Economy

Engine Pro Diesel Performance Cams are designed to maximize the performance of these engines within the OEM RPM limits. The opening and closing valve events and lobe ramp design are changed resulting in more power and better fuel economy. Other benefits include reduced turbo lag, faster spooling and more efficient boost.

For Ford Powerstroke, GM Duramax and Dodge Cummins Engines

- Average horsepower increase of 50 hp confirmed in dyno tests
- Average torque increase of 100 ftlbs confirmed in dyno tests
- Reduced turbo lag confirmed in dyno tests
- Faster spooling
- Fuel economy increase of up to 22%
- Exhaust gas temperature reduced an average of 300 degrees F.
- No piston change or valve relief machining necessary
- May be used with stock or ported heads

NOTE:

It is illegal to use Engine Pro Performance Camshafts in vehicles that are operated on the public streets and highways of California. Various other state laws may limit the use of these camshafts to "off highway" applications only. Check current state and federal laws to be sure.

APPLICATION		DUR @ .050		ADV DUR		VALVE LIFT		LOBE SEP		LASH COLD		PART #
		INT	EXH	INT	EXH	INT	EXH	INT	EXH	INT	EXH	
DODGE CUMMINS 5.9L - 24 VALVES	MECH	199	199	237	237	.442	.429	112	112	.010	.020	MC59024
SPRING PRESSURE - SEAT: 135-145 OPEN: 400 (MAX)		WARNING: MUST USE 12-VALVE LIFTERS WITH THIS CAM, E.G. 2302										
FORD POWERSTROKE 6.0L, 6.4L	HYD	189	187	227	223	.364	.341	112	112	0	0	MC60641
SPRING PRESSURE - SEAT: 135-145 OPEN: 400 (MAX)		NOTE: BOOST PRESSURE WILL AFFECT THE SPRING RATE NEEDED										
FORD POWERSTROKE 6.7L	HYD	205	203	264	264	.398	.383	112	112	0	0	MC67001
SPRING PRESSURE - SEAT: 90-145 OPEN: 400 (MAX)		NOTE: BOOST PRESSURE WILL AFFECT THE SPRING RATE NEEDED										
FORD POWERSTROKE 7.3L	HYD	189	189	234	234	.432	.416	112	112	0	0	MC73001
SPRING PRESSURE - SEAT: 135-145 OPEN: 400 (MAX)		WARNING: WITHOUT MECHANICAL FUEL TRANSFER PUMP LOBE										
GM DURAMAX 6.6L	MECH	181	169	219	206	.340	.338	112	112	.000*	.002*	MC66001
SPRING PRESSURE - SEAT: 135-145 OPEN: 400 (MAX)		NOTE: BOOST PRESSURE WILL AFFECT SPRING RATE NEEDED										

* Lash will increase as cylinder head temperature increases

ENGINE PRO PERFORMANCE CAMS FOR AUTOS AND LIGHT TRUCKS

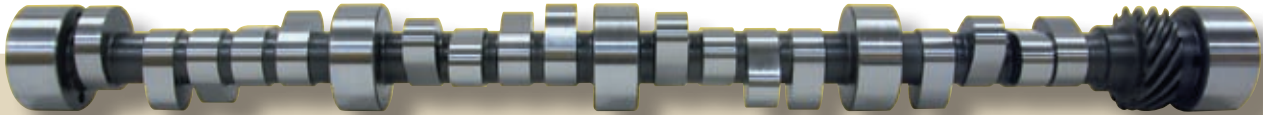

CAMSHAFT RANGE & SELECTION CHART

SEE INDIVIDUAL LISTINGS FOR MORE INFORMATION

TORQUE CAM

NEED A GOOD TORQUE CAM?
LOOK FOR THIS ICON IN THE LISTINGS

STAGE 1

DURATION @ .050": UP TO 200 HYDRAULIC	CHARACTERISTICS	RECOMMENDATIONS
	IDLE QUALITY: SMOOTH STOCK	TOWING: GOOD FOR PULLING HEAVY LOADS
	TORQUE: IMPROVED LOW END, 1600-2000 RPM	RACING: NOT RECOMMENDED
	FUEL ECONOMY: VERY GOOD	COMPUTER CONTROLLED VEHICLES: MODIFICATIONS NOT NEEDED
	TRANSMISSION: STOCK AUTOMATIC OR MANUAL	
	COMPRESSION RATIO: 9.0:1 OR LESS	

STAGE 2

DURATION @ .050": 200-215 HYDRAULIC	CHARACTERISTICS	RECOMMENDATIONS
	IDLE QUALITY: SMOOTH	TOWING: GOOD FOR LIGHT PULLING AND RV USE
	TORQUE: GOOD LOW AND MID-RANGES 1800-2600 RPM	RACING: NOT RECOMMENDED
	FUEL ECONOMY: GOOD	COMPUTER CONTROLLED VEHICLES: MODIFICATIONS MAY BE NEEDED
	TRANSMISSION: STOCK AUTOMATIC OR MANUAL	
	COMPRESSION RATIO: 9.5:1 OR LESS	

STAGE 3

DURATION @ .050": 210-225 HYDRAULIC	CHARACTERISTICS	RECOMMENDATIONS
	IDLE QUALITY: FAIR WITH SOME LOPE	TOWING: NOT RECOMMENDED
	TORQUE: MID-RANGE 2400-3200 RPM	RACING: MILD BRACKET RACING
	FUEL ECONOMY: FAIR	COMPUTER CONTROLLED VEHICLES: MODIFIED COMPUTER CHIP MAY BE REQUIRED TO COMPENSATE FOR LOW VACUUM
	TRANSMISSION: STOCK AUTOMATIC OR MANUAL	
	COMPRESSION RATIO: 10.3:1 OR LESS. CHECK VALVE TO PISTON CLEARANCE RATIO:	

STAGE 4

DURATION @ .050": 225-240 HYDRAULIC	CHARACTERISTICS	RECOMMENDATIONS
	IDLE QUALITY: ROUGH. MANIFOLD VACUUM WILL NOT OPERATE POWER BRAKES	TOWING: NOT RECOMMENDED
	TORQUE: MID-RANGE 3000-4000 RPM	RACING: BRACKET DRAG RACING, LIMITED OVAL TRACK
	FUEL ECONOMY: POOR	COMPUTER CONTROLLED VEHICLES: NOT RECOMMENDED
	TRANSMISSION: AUTOMATIC WITH HIGH STALL CONVERTER OR MANUAL	
	COMPRESSION RATIO: 10.5:1 TO 11.0:1. CHECK VALVE TO PISTON CLEARANCE RATIO:	

STAGE 5

DURATION @ .050": 240-255 HYDRAULIC 250-265 MECHANICAL	CHARACTERISTICS	RECOMMENDATIONS
	IDLE QUALITY: ROUGH WITH HEAVY LOPE. WILL NOT OPERATE POWER BRAKES	TOWING: NOT RECOMMENDED
	TORQUE: MID TO HIGH RANGES 3800-5000 RPM	RACING: BRACKET DRAG RACING, OVAL TRACK
	FUEL ECONOMY: POOR	COMPUTER CONTROLLED VEHICLES: NOT RECOMMENDED
	TRANSMISSION: AUTOMATIC WITH HIGH STALL CONVERTER OR HEAVY DUTY MANUAL	
	COMPRESSION RATIO: 10.5:1 TO 12.0:1. CHECK VALVE TO PISTON CLEARANCE RATIO:	

THESE ARE GENERAL GUIDELINES. TO ACHIEVE BEST PERFORMANCE, MATCH CARBURETION, INTAKE MANIFOLD, IGNITION AND HEADERS TO THE CAMSHAFT.

PERFORMANCE CAMSHAFTS

- Computer designed lobe profiles for maximum power
- Journal roundness maintained to within .0002"
- Manganese phosphate coated, flame hardened castings or induction hardened billets
- Profiles are adcole verified for the ultimate in accuracy



APPLICATION	DUR @ .050"		ADV. DUR.		VALVE LIFT		LOBE SEP		POWER	IDLE	LIFTER	PART #	NOTES	
	INT	EXH	INT	EXH	INT	EXH	INT	EXH	RANGE					
AMERICAN MOTORS V8; 1966-92 290, 304, 343, 360, 390, 401 C.I. HYDRAULIC FLAT TAPPET CAM														
TORQUE CAM STAGE 2	204	214	280	290	.448	.472	105	105	1000-5000	SMOOTH	2011	MC1786		
GOOD AND LOW MID RANGE TORQUE AND PULLING POWER.													B, D	
BUICK V6, 1978-88; 181, 196, 231, 252 C.I (EVEN FIRE W/INTEGRAL DIST. DRIVE GEAR) HYDRAULIC FLAT TAPPET CAMS														
TORQUE CAM STAGE 2	204	214	280	290	.448	.472	112	112	1200-4700	SMOOTH	969	MC2731		
GOOD LOW AND MID-RANGE TORQUE..													N	
CHEVROLET V6-1980-89; 173 C.I. (2.8L) & 1990-94 189 C.I. (3.1L) HYDRAULIC FLAT TAPPET CAM														
TORQUE CAM STAGE 2	204	214	278	288	.420	.443	107	112	1000-5000	SMOOTH	2095	MC1784		
GOOD LOW END TORQUE AND PULLING POWER.													N	
CHEVROLET-GM LS V8 GEN III & IV, 3 BOLT, 1997-PRESENT, 1.7-1 ROCKER RATIO HYDRAULIC ROLLER CAMS														
STAGE 2	204	218	-	-	.551	.548	120	115	800-5500	SMOOTH	2148	MC315271		
SIMILAR TO 2002-04 LS6 CAM.													17-7717-16	A
STAGE 2	206	212	262	268	.515	.522	110	114	1200-4800	SMOOTH	2148	MC315408		
GOOD LOW AND MID-RANGE TORQUE.													17-7717-16	
STAGE 3	212	218	274	280	.522	.529	112	116	1500-5000	FAIR	2148	MC315412		
GOOD LOW TO MID TORQUE. NOTICEABLE IDLE.													17-7717-16	
STAGE 3	218	227	-	-	.523	.524	109	115	1500-6000	FAIR	2148	MC315944		
SIMILAR TO LS "HOT CAM".													17-7717-16	A
STAGE 4	225	236	-	-	.525	.525	107	113	2000-6500	ROUGH	2148	MC315945		
SIMILAR TO ASA CAM.													17-7717-16	A
CHEVROLET SMALL BLOCK V8 1955-95; 262, 265, 267, 302, 305, 307, 327, 350, 400 C.I. HYDRAULIC FLAT TAPPET CAM														
STAGE 1	184	194	260	270	.368	.398	104	104	1000-3500	STOCK	817	MC2199		
GOOD LOW END TORQUE AND MILEAGE.														
STAGE 2	194	204	270	278	.398	.420	104	104	1500-4000	SMOOTH	817	MC2200		
GOOD FOR COMPUTER CONTROLLED ENGINES.													C	
TORQUE CAM STAGE 2	204	214	278	288	.420	.443	110	110	1500-4000	SMOOTH	817	MC2201		
GOOD FOR COMPUTER CONTROLLED ENGINES.													C	
TORQUE CAM STAGE 2	204	214	278	288	.420	.433	107	117	1500-4000	SMOOTH	817	MC1730		
STRONG TORQUE AND GOOD MILEAGE FOR 327 TO 400 C.I.														
STAGE 3	209	216	283	286	.435	.455	107	117	1500-4000	FAIR	817	MC2203		
GOOD LOW END TORQUE AND PULLING POWER.														
STAGE 3	214	214	288	288	.443	.443	107	117	2000-4000	FAIR	817	MC2204		
GOOD MARINE CAM.														
STAGE 3	214	224	288	298	.443	.465	107	117	2000-4500	FAIR	817	MC1988		
GOOD LOW TO MID TORQUE. NOTICEABLE IDLE.														
STAGE 3	218	218	292	292	.458	.458	105	115	2000-4000	FAIR	817	MC1989		
GOOD LOW TO MID TORQUE.														

CAMSHAFT APPLICATION CHART CONTINUED



APPLICATION	DUR @ .050"		ADV. DUR.		VALVE LIFT		LOBE SEP		POWER	IDLE	LIFTER	PART #	NOTES
	INT	EXH	INT	EXH	INT	EXH	INT	EXH	RANGE				
CHEVROLET SMALL BLOCK V8 1955-95; 262, 265, 267, 302, 305, 307, 327, 350, 400 C.I. HYDRAULIC FLAT TAPPET CAMS													
STAGE 3	222	222	290	290	.447	.447	110	118	2000-4000	FAIR	817	MC1713	
OEM #3863151, 350HP, L-79, 327.													
STAGE 3	224	224	291	287	.450	.460	114	114	2000-4500	FAIR	817	MC5840	
OEM #3896962, 350HP, L-82, LT-1.													
STAGE 3	224	224	298	298	.465	.465	107	117	2000-5500	FAIR	817	MC1991	
GOOD LOW TO MID TORQUE. BIGGEST CAM FOR USE W/ STOCK CONVERTER.													
STAGE 4	224	234	300	300	.465	.488	107	117	2000-5500	ROUGH	817	MC5892	
GOOD MID TORQUE. 2200 + STALL CONVERTER.													
STAGE 4	230	230	287	287	.480	.480	106	110	2000-5000	ROUGH	817	MC1993	
GOOD FOR STREET RODSWITH HIGH STALL CONVERTER.													
STAGE 4	234	244	303	313	.488	.509	107	117	2500-6500	ROUGH	817	MC1995	
STREET/STRIP MILD BRACKET RACING 2800+ STALL CONVERTER.													
STAGE 5	244	244	318	318	.510	.510	106	112	3200-7000	VERY ROUGH	817	MC1996	
GOOD FOR PRO, STREET, BRACKET, OVAL RACING. 3500 + STALL CONVERTER.													
STAGE 5	244	254	313	328	.510	.533	107	117	3500-7500	VERY ROUGH	817	MC5871	
GOOD FOR PRO, STREET, BRACKET, OVAL RACING. 3500 + STALL CONVERTER.													
CHEVROLET SMALL BLOCK V8 1955-95; 262, 265, 267, 302, 305, 307, 327, 350, 400 C.I. MECHANICAL FLAT TAPPET CAMS													
STAGE 4	240	250	282	290	.520	.520	104	108	2700-6200	.022 INT	992	MC22402	
ROUGH LOPE.													
STAGE 5	254	254	295	295	.485	.485	110	118	3200-7500	.030 INT	992	MC1612	
OEM #3849346, 290HP 302, 365/375 HP 327 HEAVY LOPE.													
STAGE 5	258	266	290	298	.538	.556	98	111	3600-7200	.030 INT	992	MC5949	
VERY ROUGH IDLE. HEAVY LOPE.													
STAGE 5	264	274	309	319	.540	.563	108	115	3600-7200	.024 INT	992	MC22450	
VERY ROUGH IDLE. HEAVY LOPE.													
CHEVROLET SMALL BLOCK V8 1987-02; FOR ENGINES ORIGINALLY EQUIPPED WITH HYDRAULIC ROLLER CAMS													
STAGE 2	198	210	273	288	.434	.462	108	116	IDLE-4500	SMOOTH	2148	MC22129	
GOOD TORQUE AND MILEAGE.													
STAGE 2	210	215	288	284	.462	.470	106	114	600-4500	SMOOTH	2148	MC22131	
GOOD TORQUE AND MILEAGE.													
STAGE 3	220	224	283	287	.495	.502	107	113	1800-5400	FAIR	2148	MC22280	
BIGGEST CAM FOR USE W/STOCK CONVERTER.													
STAGE 4	222	232	297	307	.479	.501	109	119	2000-5700	ROUGH	2148	MC22298	
GOOD FOR STREET RODS 2000+ STALL CONVERTER.													
CHEVROLET SMALL BLOCK V8 1955-95; RETRO-FIT HYDRAULIC ROLLER CAMS													
TORQUE CAM STAGE 2	206	214	266	274	.470	.490	108	116	1000-4500	SMOOTH	17-5372-16	MC22135	
STREET PERFORMANCE, SLIGHT LOPE.													
STAGE 3	210	215	288	284	.462	.470	106	114	1500-5300	FAIR	17-5372-16	MC22238	
STREET PERFORMANCE, SLIGHT LOPE.													
STAGE 3	215	224	284	296	.470	.490	108	116	1700-5200	FAIR	17-5372-16	MC22237	
GOOD MID-RANGE, NOTICEABLE IDLE.													
STAGE 3	215	230	284	310	.470	.480	106	114	1700-5500	FAIR	17-5372-16	MC22136	
MID-RANGE POWER, NOTICEABLE IDLE.													
STAGE 4	234	238	296	300	.538	.546	107	117	2500-6500	ROUGH	17-5372-16	MC22398	
HIGH PERFORMANCE STREET & STRIP. NEEDS 3000 + STALL CONVERTER.													

A - Require computer modifications
 C - Preferred choice for computer controlled engines

D - May require conversion to an adjustable valve train
 N - Not computer compatible

CAMSHAFT APPLICATION CHART CONTINUED

APPLICATION	DUR @ .050"		ADV. DUR.		VALVE LIFT		LOBE SEP		POWER	IDLE	LIFTER	PART #	NOTES
	INT	EXH	INT	EXH	INT	EXH	INT	EXH	RANGE				
CHEVROLET BIG BLOCK V8 1967-95; 396, 402, 427, 454 C.I. / 1969-90 366 C.I. (CHAIN DRIVE) HYDRAULIC FLAT TAPPET CAMS													
STAGE 1	190	202	260	272	.439	.464	106	114	IDLE-4500	SMOOTH	817	MC22127	
GOOD FUEL ECONOMY.													
TORQUE CAM STAGE 2	204	208	288	298	.459	.459	108	116	1000-4500	SMOOTH	817	MC2004	
GOOD LOW AND MID RANGE TORQUE. GOOD FUEL ECONOMY.													
STAGE 3	214	214	292	292	.501	.501	109	119	2000-4000	FAIR	817	MC2006	
GOOD LOW TO MID TORQUE.													
STAGE 3	214	218	289	302	.461	.481	110	120	2000-4000	FAIR	817	MC1953	
OEM #3904359 L34 350-360HP 396, 390HP 427, GOOD MARINE CAM.													
STAGE 3	214	224	292	302	.501	.527	108	116	2000-5500	FAIR	817	MC1737	
GOOD LOW END TORQUE AND TOWING POWER.													
STAGE 4	222	235	306	322	.500	.505	110	120	1500-4000	ROUGH	817	MC1636	
GOOD LOW TO MID TORQUE.													
STAGE 4	224	224	293	293	.510	.510	114	117	1500-4000	ROUGH	817	MC1958	
GOOD MARINE CAMSHAFT.													
STAGE 4	224	232	302	304	.527	.553	110	118	2500-6000	ROUGH	817	MC2305	
HIGH PERFORMANCE STREET, STRONG MID-RANGE.													
STAGE 5	240	246	305	311	.559	.572	110	114	3200-6700	VERY ROUGH	817	MC22471	
GOOD FOR PRO, STREET, BRACKET, OVAL RACING. 3500 + STALL CONVERTER.													
CHEVROLET BIG BLOCK V8 1967-95; 396, 402, 427, 454 C.I. MECHANICAL FLAT TAPPET CAMS													
STAGE 4	242	242	310	297	.508	.496	108	120	3200-7000	.020 INT	992	MC22396	
OEM #3904362, 9.5:1 COMP., 3000 STALL CONVERTER OR STICK, LOWER GEARS.													
.024 EXH 17-5035-16 N													
CHEVROLET BIG BLOCK V8 1996-00; 454 C.I. FOR ENGINES ORIGINALLY EQUIPPED WITH HYDRAULIC ROLLER CAMS													
STAGE 4	236	246	316	324	.561	.578	106	114	2600-6300	ROUGH	2279	MC22485	
STREET STRIP, 3500+ STALL CONVERTER.													
STAGE 5	241	246	305	310	.559	.572	110	114	2800-6200	VERY ROUGH	2279	MC22480	
SERIOUS STREET/STRIP 3000+ STALL CONVERTER.													
CHEVROLET BIG BLOCK V8 1967-95; 396, 402, 427, 454 C.I. RETRO-FIT HYDRAULIC ROLLER CAMS													
STAGE 2	216	228	288	300	.502	.510	108	116	1700-5200	SMOOTH	17-5374-16	MC22141	
PERFORMANCE WITH GOOD MID-RANGE TORQUE.													
STAGE 3	224	234	296	308	.527	.544	106	114	2200-5700	FAIR	17-5374-16	MC22236	
PERFORMANCE STREET CAM, 9.5:1 COMP., 2000+ STALL CONVERTER.													

D - May require conversion to an adjustable valve train

E - Base circle size of camshaft is smaller than stock size. Special push rods or rocker arms may be required to keep geometry correct and avoid damage

G - The base circle size of the camshaft may require conversion to an adjustable valve train

N - Not computer compatible.



ENGINEPROSHOPSOLUTIONS.COM

MORE ON CAM GEAR CLEARANCING

I recently read a Shop Solution about using a cam and cam gear to test for gear to block clearance on late small block Chevy blocks. Well, here is our tool I've used for years. It's an aluminum hub that's .002 under cam bearing bore size so a guy can do it when the block is stripped and cleaned. We turned down the scrap aluminum in our shop on the lathe, where it was also drilled and tapped. This can save you from damaging a new cam bearing and it is much easier to handle than a gear with the camshaft hanging off of it.

Randy Torvinen Torvinen's Machine Menahga, MN July, 2014



MORE ENGINE PRO SHOP SOLUTIONS

CAMSHAFT APPLICATION CHART CONTINUED



APPLICATION	DUR @ .050"		ADV. DUR.		VALVE LIFT		LOBE SEP		POWER	IDLE	LIFTER	PART #	NOTES
	INT	EXH	INT	EXH	INT	EXH	INT	EXH	RANGE				
CHRYSLER V8 1964-89; 273, 340, 360 C.I. / 1967-89 318 C.I. HYDRAULIC FLAT TAPPET CAMS													
STAGE 2	210	220	279	290	.429	.442	108	116	1500-4000	SMOOTH	2011	MC1735	
OEM #2899206 275HP-340. STRONG LOW TO MID TORQUE. STRONG PULLING POWER. GOOD MILEAGE.													
STAGE 3	214	224	288	298	.443	.466	108	116	2000-4800	FAIR	2011	MC3203	
GOOD LOW AND STRONG MID RANGE TORQUE.													
CHRYSLER V8 1958-78; 383, 400, 413, 426 (EXC HEMI), 440 C.I. / "B" ENGINE-HYDRAULIC FLAT TAPPET CAMS (USE WITH SINGLE BOLT GEAR)													
TORQUE CAM STAGE 2	204	214	278	288	.420	.443	107	117	1500-4000	SMOOTH	812 (E)	MC1787	
STRONG LOW TO MID RANGE TORQUE AND PULLING POWER.											976 (L)		
STAGE 3	213	225	292	309	.449	.464	113	117	2000-4500	SMOOTH	812 (E)	MC2323	
OEM #2843564 375HP-440. STRONG LOW TO MID TORQUE.											976 (L)		
STAGE 3	224	224	289	289	.455	.455	107	117	2000-4500	FAIR	812 (E)	MC2032	
GOOD LOW TO MIDDLE TORQUE.											976 (L)	E	
STAGE 4	236	236	302	302	.480	.480	108	108	2500-6000	ROUGH	812 (E)	MC23302	
STREET & STRIP, NEEDS 9.5:1 COMPRESSION, 2500+ STALL CONVERTER.											976 (L)	N	
FORD V8 1962-91; 260, 289, 302 C.I. (EXCEPT 1982-85 302 H.O.) FIRING ORDER 1-5-4-2-6-3-7-8 HYDRAULIC FLAT TAPPET CAMS													
STAGE 2	190	202	258	271	.413	.437	106	114	1000-4000	SMOOTH	900	MC4120	
GOOD LOW END TORQUE. GOOD FOR TOWING.													
TORQUE CAM STAGE 2	204	214	280	289	.448	.472	108	116	1500-4000	SMOOTH	900	MC1734	
STRONG LOW END TORQUE. GOOD FOR TOWING. GOOD MILEAGE.													G
STAGE 2	218	218	298	298	.460	.460	106	120	1700-5200	FAIR	900	MC24212	
OEM #C90Z-6250-C 225HP-289 PERFORMANCE STEEET CAM WITH MID-RANGE POWER, BEST WITH SLIGHTLY LOWER GEARS.													N
STAGE 3	214	224	290	300	.472	.496	108	116	2000-4500	FAIR	900	MC2057	
GOOD LOW AND MID RANGE TORQUE AND PULLING POWER.													G
STAGE 4	231	231	288	288	.512	.512	106	114	2500-5800	ROUGH	900	MC2292	
STREET AND MILD BRACKET.													
FORD V8 1985-92; 302 C.I. (5.0L) FIRING ORDER 1-3-7-2-6-5-4-8 ORIGINALLY EQUIPPED WITH HYDRAULIC ROLLER CAMS													
STAGE 2	210	211	292	282	.444	.444	116	115	1200-4600	SMOOTH	2005	MC24110	
FOR STOCK ENGINE. GOOD ECONOMY AND TORQUE.											17-5323-16		
STAGE 3	212	222	289	299	.493	.510	107	117	1200-5000	FAIR	2205	MC24226	
WORKS WITH STOCK CONVERTER, GOOD STREET PERFORMANCE.											17-5323-16	N	
STAGE 3	219	219	285	285	.498	.498	110	110	1700-5300	FAIR	2005	MC24214	
STREET CAM WITH GOOD HIGH END POWER AND TORQUE.											17-5323-16	N	
STAGE 3	220	223	286	292	.512	.512	109	115	2000-5500	FAIR	2005	MC24280	
STREET HOT ROD, BEST POWER ABOVE 3500, 1800+ STALL CONVERTER.											17-5323-16	N	
STAGE 4	222	232	299	309	.510	.534	107	117	2200-6200	ROUGH	2205	MC24227	
STREET/STRIP, 5 SPEED OR 2500+ STALL CONVERTER.											17-5323-16	N	
STAGE 4	227	234	298	302	.520	.520	107	117	2200-5400	ROUGH	2005	MC24305	
GOOD STREET PERFORMANCE WITH 2500 STALL CONVERTER, GOOD TORQUE.											17-5323-16	N	

E - Base circle size of camshaft is smaller than stock size. Special push rods or rocker arms may be required to keep geometry correct and avoid damage

G - The base circle size of the camshaft may require conversion to an adjustable valve train

N - Not computer compatible

It is illegal to use Engine Pro Performance Camshafts in vehicles that are operated on the public streets and highways of California. Various other state laws may limit the use of these camshafts to "off highway" applications only. Check current state and federal laws to be sure.

CAMSHAFT APPLICATION CHART CONTINUED

APPLICATION	DUR @ .050"		ADV. DUR.		VALVE LIFT		LOBE SEP		POWER	IDLE	LIFTER	PART #	NOTES
	INT	EXH	INT	EXH	INT	EXH	INT	EXH	RANGE				
FORD V8 351W 1969-91; 302 C.I., H.O. 1982-85 FIRING ORDER 1-3-7-2-6-5-4-8 HYDRAULIC FLAT TAPPET CAMS													
TORQUE CAM STAGE 2	204	214	280	290	.448	.472	107	117	1500-4000	SMOOTH	900	MC1775	
GOOD LOW AND MID RANGE TORQUE FOR TRUCKS AND TOWING.													
STAGE 3	219	219	308	308	.467	.467	107	119	2000-4000	FAIR	900	MC4225	
GOOD LOW TO MID RANGE TORQUE.													
STAGE 4	224	234	300	304	.496	.502	107	117	2200-5400	ROUGH	900	MC24211	
STREET PERFORMANCE. GOOD MID & HIGH END, 2500 + STALL CONVERTER.													
NOTE: THESE CAMSHAFTS CAN BE USED IN 221 THRU 302 C.I. ENGINES BY CHANGING TO FIRING ORDER 1-3-7-2-6-5-4-8.													
FORD V8 1970-82; 351C, 351M, 400 C.I. HYDRAULIC FLAT TAPPET CAMS													
TORQUE CAM STAGE 2	204	214	282	292	.484	.510	106	118	1500-4000	SMOOTH	900	MC1733	
GOOD LOW AND MID RANGE TORQUE. GOOD FOR TOWING.													
STAGE 3	214	224	292	302	.510	.536	106	118	1700-5500	FAIR	900	MC24204	
GOOD THROTTLE RESPONSE, GOOD MID-RANGE, 2000+ STALL CONVERTER.													
FORD V8 1963-76; 352, 360, 390, 406, 410, 427, 428 C.I. "FE" ENGINE HYDRAULIC FLAT TAPPET CAMS													
TORQUE CAM STAGE 2	204	214	282	292	.484	.510	104	120	1500-4000	SMOOTH	2083	MC1776	
GOOD LOW END TORQUE. GOOD FOR TOWING													
STAGE 3	214	224	292	302	.510	.536	104	120	2000-4500	FAIR	2083	MC4205	
STRONG LOW END TORQUE. GOOD FOR TOWING. GOOD MILEAGE.													
FORD V8 1968-97; 370, 429, 460 C.I. HYDRAULIC FLAT TAPPET CAMS													
TORQUE CAM STAGE 2	204	214	282	292	.484	.512	107	117	1500-4000	SMOOTH	900	MC1732	
GOOD LOW END TORQUE. GOOD FOR TOWING.													
STAGE 3	214	224	292	302	.510	.536	107	117	2000-4800	FAIR	900	MC2311	
STRONG LOW AND MID RANGE TORQUE. GOOD FOR HEAVY TOWING.													
OLDSMOBILE V8 1967-85; (30 DEGREE BANK ANGLE)													
TORQUE CAM STAGE 2	204	214	280	295	.448	.472	106	118	1500-4000	SMOOTH	951	MC1777	
GOOD LOW END TORQUE AND PULLING POWER.													
STAGE 3	214	224	290	300	.472	.496	106	118	2000-4500	FAIR	951	MC2101	D
GOOD LOW TO MID RANGE TORQUE. STOCK TORQUE CONVERTER.													
STAGE 4	232	232	308	308	.474	.474	107	119	2650-6200	ROUGH	951	MC2104	D
SIMILAR TO OEM # 409691 350 W31 AND 1ST SERIES 400 W30.													
STAGE 4	244	244	328	328	.474	.474	110	110	3200-6700	ROUGH	951	MC1644	D
SIMILAR TO OEM # 402569 2ND SERIES 455 W30 1968 ON.													
PONTIAC V8 1955-81; 265, 287, 301, 316, 326, 347, 350, 370, 389, 400, 421, 428, 455 C. I. HYDRAULIC FLAT TAPPET CAMS													
TORQUE CAM STAGE 2	204	214	278	288	.420	.443	108	116	1500-4000	SMOOTH	951	MC1778	
GOOD LOW END TORQUE AND PULLING POWER. GOOD MILEAGE.													
STAGE 3	214	224	288	298	.443	.465	106	118	2000-4500	FAIR	951	MC1130	
GOOD LOW AND MID RANGE TORQUE. GOOD MILEAGE. STRONG PULLING POWER													
STAGE 4	224	236	301	313	.407	.407	112	119	2650-6200	ROUGH	951	MC26303	
SIMILAR TO OEM # 9794041 400 RAM AIR III AND 455SD													
STAGE 4	231	240	308	320	.470	.470	112	115	3200-6700	ROUGH	951	MC26308	
SIMILAR TO OEM # 9785744 400 RAM AIR IV WITH 1.5:1 RATIO ROCKER ARM.													

D - May require conversion to an adjustable valve train

E - Base circle size of camshaft is smaller than stock size. Special push rods or rocker arms may be required to keep geometry correct and avoid damage

G - The base circle size of the camshaft may require conversion to an adjustable valve train

N - Not computer compatible

PREMIUM BILLET PRO ADJUST TIMING SETS

- .250 seamless roller chain
- 2-piece cam sprocket infinitely adjustable from +6 to -6 degrees except LS applications which use 5-Piece dowel pin insert kit for +/- 4 degree cam adjustment
- ARP adjusting bolts, except LS
- CNC heat treated steel crank sprocket, LS has 9-keyways
- Press fit Torrington roller thrust bearing
- Cam timing adjustable with valve covers installed
Not necessary to back-off rocker arms

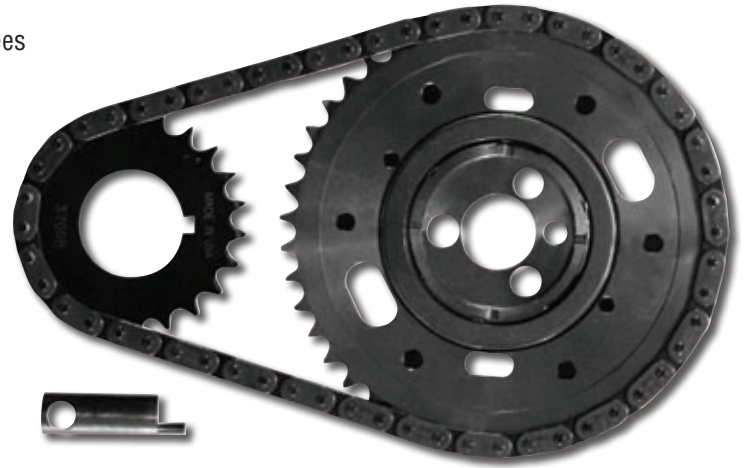

APPLICATION	PREMIUM PRO ADJUST PART #	PREMIUM PRO ADJUST W/ IWIS CHAIN PART #
CHEVROLET SMALL BLOCK; 1955-95 NON-FACTORY ROLLER	08-4700	08-4700G
-0.005 CENTER DISTANCE REDUCED	08-4700-005	08-4700-005G
-0.010 CENTER DISTANCE REDUCED	08-4700-010	08-4700-010G
ROCKET BLOCK W/SB CHEVY CRANK SNOUT	08-4760	08-4760G
BB CHEVY CRANK SNOUT	08-4765	08-4765G
RAISED CAM W/BB CHEVY CRANK SNOUT	08-4766	08-4766G
CHEVROLET LS1; 294 (4.8-V), 323 (5.3-T,Z,P), 346 (5.7-G,S), 364 (6.0-N,U) 1997-04 3-BOLT NO SENSOR CAM	08-4714R	08-4714G
CHEVROLET LS2; 364 (6.0-N,U) 2005, LS6 - 346 (5.7) 2004-05 - 3-BOLT 1-SENSOR CAM	08-4714R	08-4714G
-0.005 CENTER DISTANCE REDUCED	08-4714-005R	08-4714-005G
-0.010 CENTER DISTANCE REDUCED	08-4714-010R	08-4714-010G
CHEVROLET LS2; 364 (6.0-N,U) 2006-07, LS3 -376(6.2) 2007- 3-BOLT - 4 SENSOR CAM	08-4736R	08-4736G
-0.005 CENTER DISTANCE REDUCED	08-4736-005R	08-4736-005G
-0.010 CENTER DISTANCE REDUCED	08-4736-010R	08-4736-010G
CHEVROLET LS7; 427 (7.0) Z06, 2006-11 - 3-BOLT - 4 SENSOR CAM	08-4777R	08-4777G
-0.005 CENTER DISTANCE REDUCED	08-4777-005R	08-4777-005G
-0.010 CENTER DISTANCE REDUCED	08-4777-010R	08-4777-010G
CHEVROLET BIG BLOCK - 1965-90	08-4710	08-4710G
CHRYSLER-V8; 345(5.7) 370(6.1) HEMI - 2003-10 W/O TORRINGTON BEARING	08-4705R	08-4705G
WITH TORRINGTON BEARING	08-4705TR	08-4705TG
FORD SMALL BLOCK; 1 PIECE FUEL PUMP ECCENTRIC LATE 1965-EARLY 72	08-4720*	08-4720G*
FORD SMALL BLOCK; 2 PIECE FUEL PUMP ECCENTRIC - LATE 1972-88	08-4751*	08-4751G*
FORD; 429,460 W/FACTORY TDC TIMING	08-4730	08-4730G

ROLON CHAIN UPGRADE NOW AVAILABLE ON THE ABOVE PERFORMANCE SETS

- Features less wear and elongation'
- Add 'R' suffix when ordering
- Higher tensile strength chromised pin for extreme duty conditions
- Recommended for applications exceeding 6500 RPM

IWIS GERMAN CHAIN

- Acoustically balanced for excellent wear resistance
- Designed for high speed applications

PREMIUM BILLET LS SINGLE ROLLER .250 PRO ADJUST

- Single Roller .250 heavy duty chain, heat treated and polished
- Billet steel cam sprocket with press fit thrust bearing
- 5-Piece dowel pin insert kit for +/- 4 degree cam adjustment
- Billet steel crank sprocket, heat treated & 9-keyway
- Billet steel oil pump drive sprocket

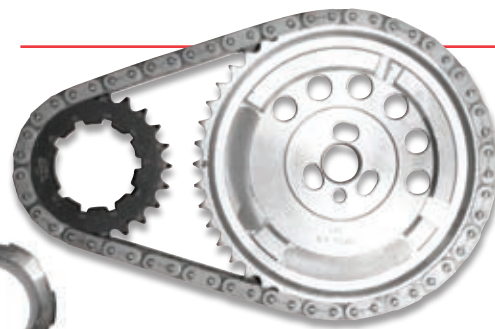

APPLICATION	PREMIUM PRO ADJUST PART #	PREMIUM PRO ADJUST W/ IWIS CHAIN PART #
CHEVROLET LS1; 294 (4.8-V), 323 (5.3-T,Z,P), 346 (5.7-G,S), 364 (6.0-N,U) 1997-04; 3-BOLT NO SENSOR CAM	08-9014T-9A	08-9014T-9AG
CHEVROLET LS2; 364 (6.0-N,U) 2005, LS6 - 346 (5.7) 2004-05 - 3-BOLT 1-SENSOR CAM	08-9014T-9A	08-9014T-9AG
-0.005 CENTER DISTANCE REDUCED	08-9014T-9A-005	08-9014T-9A-005G
-0.010 CENTER DISTANCE REDUCED	08-9014T-9A-010	08-9014T-9A-010G
CHEVROLET LS2; 364 (6.0-N,U) 2006-07, LS3 -376(6.2) 2007 -3-BOLT - 4 SENSOR CAM	08-9036T-9A	08-9036T-9AG
-0.005 CENTER DISTANCE REDUCED	08-9036T-9A-005	08-9036T-9A-005G
-0.010 CENTER DISTANCE REDUCED	08-9036T-9A-010	08-9036T-9A-010G
CHEVROLET LS7; 427 (7.0) Z06, 2006-11 -3-BOLT - 4 SENSOR CAM	08-9077T-9A	08-9077T-9AG
-0.005 CENTER DISTANCE REDUCED	08-9077T-9A-005	08-9077T-9A-005G
-0.010 CENTER DISTANCE REDUCED	08-9077T-9A-010	08-9077T-9A-010G

PREMIUM BILLET .250 ROLLER

- .250 seamless roller chain
- CNC billet steel cam sprocket
- CNC heat treated steel 9-keyway crank sprocket
- Press fit Torrington roller thrust bearing (T) on most applications

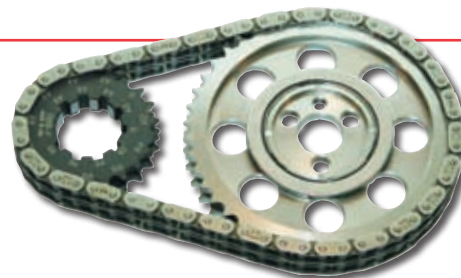

APPLICATION	PREMIUM BILLET PART #	PREMIUM BILLET W/ IWIS CHAIN PART #
AMC JEEP; 150 1983-02, 199, 232, 242 (4.0L), 258 1965-98	08-2080-9R	
AMC JEEP; 242 (4.0L) 1999-06	08-2081-9R	
BUICK; 400,430,455, 1967-76	08-2040	08-2040G
CHEVROLET SMALL BLOCK; 1955-95 NON-FACTORY ROLLER	08-2001T-9	08-2001T-9G
-0.005 CENTER DISTANCE REDUCED	08-2001T-9-005	08-2001T-9-005G
-0.010 CENTER DISTANCE REDUCED	08-2001-T-9-010	08-2001-T-9-010G
ROCKET BLOCK W/SB CHEVY CRANK SNOUT	08-2060T-9	08-2060T-9G
BB CHEVY CRANK SNOUT	08-2065T-9	08-2065T-9G
RAISED CAM W/BB CHEVY CRANK SNOUT	08-2066T-9	08-2066T-9G
CHEVROLET SMALL BLOCK; 1986 UP - W/FACTORY ROLLER CAM	08-2021T-9	08-2021T-9G
-0.005 CENTER DISTANCE REDUCED	08-2021T-9-005	08-2021T-9-005G
-0.010 CENTER DISTANCE REDUCED	08-2021T-9-010	08-2021T-9-010G



APPLICATION	PREMIUM BILLET PART #	PREMIUM BILLET W/ IWIS CHAIN PART #
CHEVROLET LS1; 294 (4.8-V), 323 (5.3-T,Z,P), 346 (5.7-G,S), 364 (6.0-N,U) 1997-04		
3-BOLT NO SENSOR CAM	08-2013T-9	08-2013T-9G
-.005 CENTER DISTANCE REDUCED	08-2013T-9-005	08-2013T-9-005G
-.010 CENTER DISTANCE REDUCED	08-2013T-010	08-2013T-010G
CHEVROLET LS2; 364 (6.0-N,U) 2005, LS6 - 346 (5.7) 2004-05 - 3-BOLT 1 SENSOR CAM	08-2014T-9	08-2014T-9G
-.005 CENTER DISTANCE REDUCED	08-2014T-9-005	08-2014T-9-005G
-.010 CENTER DISTANCE REDUCED	08-2014T-9-010	08-2014T-9-010G
CHEVROLET LS2; 364 (6.0-N,U) 2006-07, LS3 -376(6.2) 2007 - 3-BOLT 4 SENSOR CAM	08-2036T-9	08-2036T-9G
-.005 CENTER DISTANCE REDUCED	08-2036T-9-005	08-2036T-9-005G
CHEVROLET LS2; (6.0L) 05-10, LS3 (6.2L) 07-10 - 1 BOLT 4 SENSOR CAM	08-2035T-9	08-2035T-9G
-.005 CENTER DISTANCE REDUCED	08-2035T-9-005	08-2035T-9-005G
CHEVROLET LS7; 427 (7.0) Z06, 2006-11	08-2077T-9	08-2077T-9G
CHEVROLET BIG BLOCK; 1965-90	08-2002T-9	08-2002T-9G
-.005 CENTER DISTANCE REDUCED	08-2002T-9-005	08-2002T-9-005G
-.010 CENTER DISTANCE REDUCED	08-2002T-010	08-2002T-010G
RAISED CAM TUNNEL	08-2047T-9R	08-2047T-9G
CHEVROLET BIG BLOCK; GENVI - 454(7.4,J) - 1996-00	08-2037T-9	08-2037T-9G
CHRYSLER - V8; 318,340,360,354,392; V6 239	08-2004-9	08-2004-9G
CHRYSLER - V8; 345(5.7) 370(6.1) HEMI - 2003-10	08-2011-9	08-2011-9G
WITH TORRINTON BEARING	08-2011T-9	08-2011T-9G
CHRYSLER - V8; 383,400,426,440, HEMI - 3 BOLT CAM	08-2005T-9	08-2005T-9G
CHRYSLER - V8; 383,400,426W, 440 - 1 BOLT CAM	08-2010-9	08-2010-9G
FORD SMALL BLOCK; 1 PIECE FUEL PUMP ECCENTRIC LATE 1965-EARLY 72	08-2003T-9*	08-2003T-9G*
-.005 CENTER DISTANCE REDUCED	08-2003T-9-005*	08-2003T-9-005G*
-.010 CENTER DISTANCE REDUCED	08-2003T-9-010	08-2003T-9-010G
FORD SMALL BLOCK; 2 PIECE FUEL PUMP ECCENTRIC - LATE 1972-88	08-2023T-9*	08-2023T-9G*
-.005 CENTER DISTANCE REDUCED	08-2023T-9-005*	08-2023T-9-005G*
-.010 CENTER DISTANCE REDUCED	08-2023T-9-010*	08-2023T-9-010G*
FORD; 351C,351M,400	08-2008T-9	08-2008T-9G
FORD; 360,390,427,428	08-2006T-9	08-2006T-9G
FORD; 429, 460 W/FACTORY TDC TIMING	08-2009T-9	08-2009T-9G
- WITH DUAL CAM DOWEL PINS	08-2009T-9DR	
PONTIAC; 350P, 400, 428, 455 (PREMIUM BILLET SET HAS BRONZE BUSHING)	08-2007W-9	08-2007W-9G

* SBF Application Require 08-7820TPK Thrust Plate with Countersunk Screws

ROLON CHAIN UPGRADE NOW AVAILABLE ON THE ABOVE PERFORMANCE SETS

- Features less wear and elongation
- Add 'R' suffix when ordering
- Higher tensile strength chromised pin for extreme duty conditions
- Recommended for applications exceeding 6500 RPM

IWIS GERMAN CHAIN

- Acoustically balanced for excellent wear resistance
- Designed for high speed applications

LS SINGLE ROLLER .250 PREMIUM BILLET

- Single Roller .250 heavy duty chain, heat treated and polished
- Billet steel cam sprocket with press fit thrust bearing
- Press fit Torrington thrust bearing
- Billet steel crank sprocket, heat treated & 9-keyway
- Billet steel oil pump drive sprocket

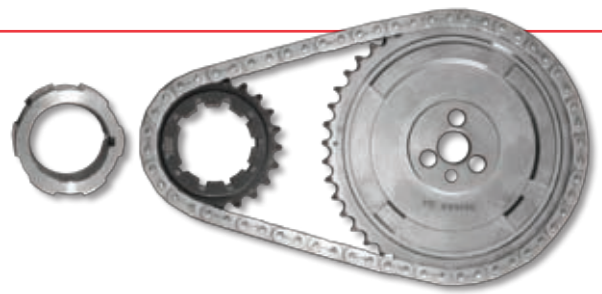

APPLICATION	PREMIUM BILLET PART #	PREMIUM BILLET W/ IWIS CHAIN PART #
CHEVROLET 4.8L, 5.3L; (99-06) LS6 5.7L (04-05) 3 BOLT CAM, NO SENSOR	08-9014T-9	08-9014T-9G
CHEVROLET LS1 5.7L; (97-04) LS2 6.0L (97-05) 3 BOLT CAM, 1 SENSOR	08-9014T-9	08-9014T-9G
-0.005 CENTER DISTANCE REDUCED	08-9014T-9-005	08-9014T-9-005G
-0.010 CENTER DISTANCE REDUCED	08-9014T-9-010	08-9014TT-9-010G
CHEVROLET LS2 6.0L; (06-07) L92 6.2L (07) 3 BOLT CAM , 4 SENSORS	08-9036T-9	08-9036T-9G
-0.005 CENTER DISTANCE REDUCED	08-9036T-9-005	08-9036T-9-005G
-0.010 CENTER DISTANCE REDUCED	08-9036T-9-010	08-9036T-9-010G
CHEVROLET 4.8L, 5.3L; (07-10) LS3 6.2L (07-10) LS2 6.0L (05-10) 1 BOLT CAM, 4 SENSORS	08-9035T-9	08-9035T-9G
-0.005 CENTER DISTANCE REDUCED	08-9035T-9-005	08-9035T-9-005G
-0.010 CENTER DISTANCE REDUCED	08-9035T-9-010	08-9035T-9-010G
CHEVROLET LS7 427, 7.0L; Z06, 2006-11 3 BOLT - 4 SENSOR CAM	08-9077T-9	08-9077T-9G
-0.005 CENTER DISTANCE REDUCED	08-9077T-9-005	08-9077T-9-005G
-0.010 CENTER DISTANCE REDUCED	08-9077T-9-010	08-9077T-9-010G

STREET STRIP .250 ROLLER AND TORRINGTON BEARING

- .250 seamless roller chain • Cast iron cam sprocket
- 3-keyway heat treated steel crank sprocket with +/- 4 degrees cam adjustment or CNC heat treated steel 9-keyway crank sprocket with 2, 4, 6 & 8 degree adjustment
- Press fit Torrington roller thrust bearing (T) on most applications

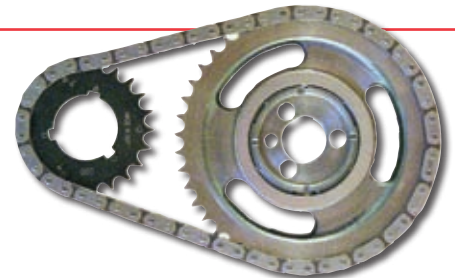

APPLICATION	STREET/STRIP PART #	STREET/STRIP W/ IWIS CHAIN PART #
CHEVROLET SMALL BLOCK; 1955-95 NON-FACTORY ROLLER	08-1100T	08-1100TG
-0.005 CENTER DISTANCE REDUCED	08-1100T-005	
-0.010 CENTER DISTANCE REDUCED	08-1100T-010	
CHEVROLET SMALL BLOCK; 1955-95 NON-FACTORY ROLLER 9-KEYWAY	08-1100T-9	08-1100T-9G
-0.005 CENTER DISTANCE REDUCED	08-1100T-9-005	
CHEVROLET BIG BLOCK; 1965-90	08-1110T	08-1110TG
-0.005 CENTER DISTANCE REDUCED	08-1110T-005	
CHEVROLET BIG BLOCK; 1965-90 9-KEYWAY	08-1110T-9	08-1110T-9G
-0.005 CENTER DISTANCE REDUCED	08-1110T-9-005	
-0.010 CENTER DISTANCE REDUCED	08-1110T-9-010	
FORD SMALL BLOCK; 2 PIECE FUEL PUMP ECCENTRIC - LATE 1972-88 9-KEYWAY	08-1138T-9	08-1138T-9G

ROLON CHAIN UPGRADE NOW AVAILABLE ON THE ABOVE PERFORMANCE SETS

- Features Less Wear and Elongation' • Add 'R' Suffix when ordering
- Higher Tensile Strength Chromised Pin for Extreme Duty Conditions
- Recommended for Applications Exceeding 6500 RPM

IWIS GERMAN CHAIN:

- Acoustically balanced for excellent wear resistance
- Designed for High Speed Applications

STREET-STRIP .250 ROLLER

- .250 seamless roller chain
- 3-keyway heat treated steel crank sprocket with +/- 4 degrees cam adjustment or CNC heat treated steel 9-keyway crank sprocket with 2, 4, 6 & 8 degree adjustment
- Cast iron cam sprocket

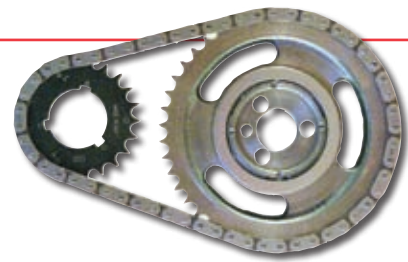

APPLICATION	STREET/STRIP PART #	STREET/STRIP W/ IWIS CHAIN PART #
AMC JEEP V8; 290,304,343,360,390,401	08-1118	08-1118G
BUICK V6; WITH INTEGRAL DISTRIBUTOR DRIVE	08-1134	08-1134G
BUICK V6 AND 215, 300, 340, 350 V8; WITHOUT INTEGRAL DISTRIBUTOR DRIVE	08-1132	08-1132G
CHEVROLET SMALL BLOCK - 1955-95	08-1100	08-1100G
-0.005 CENTER DISTANCE REDUCED	08-1100-005	08-1100-005G
-0.010 CENTER DISTANCE REDUCED	08-1100-010	08-1100-010G
9-KEY	08-1100-9	08-1100-9G
CHEVROLET SMALL BLOCK; 1986 UP - W/FACTORY ROLLER CAM	08-1145	08-1145G
-0.005 CENTER DISTANCE REDUCED	08-1145-005	08-1145-005G
-0.010 CENTER DISTANCE REDUCED	08-1145-010	08-1145-010G
9-KEY	08-1145-9	
CHEVROLET V8; 348, 409 - 1958-65	08-1101	08-1101G
CHEVROLET BIG BLOCK; 1965-90	08-1110	08-1110G
-0.005 CENTER DISTANCE REDUCED	08-1110-005	08-1110-005G
-0.010 CENTER DISTANCE REDUCED	08-1110-010	08-1110-010G
9-KEY	08-1110-9	08-1110-9G
CHRYSLER V8; 318,340,360,354,392; V6 239	08-1103	08-1103G
9-KEY	08-1103-9	
CHRYSLER V8; 383,400,426,440, HEMI - 3 BOLT CAM	08-1125	08-1125G
9-KEY	08-1125-9	
CHRYSLER V8; 383,400,426W, 440 - 1 BOLT CAM	08-1104	08-1104G
9-KEY	08-1104-9	
FORD SMALL BLOCK; 1 PIECE FUEL PUMP ECCENTRIC LATE 1965-EARLY 72	08-1135	08-1135G
-0.005 CENTER DISTANCE REDUCED	08-1135-005	08-1135-005G
-0.010 CENTER DISTANCE REDUCED	08-1135-010	08-1135-010G
9-KEY	08-1135-9	08-1135-9G
FORD SMALL BLOCK; 2 PIECE FUEL PUMP ECCENTRIC - LATE 1972-88	08-1138	08-1138G
9-KEY	08-1138-9	08-1138-9G
FORD; 351C,351M,400	08-1121	08-1121G
9-KEY	08-1121-9	
FORD; 360,390,427,428	08-1108	08-1108G
9-KEY	08-1108-9	
FORD; 429,460 W/FACTORY TDC TIMING	08-1122	08-1122G
9-KEY	08-1122-9	
OLDSMOBILE; 260,307,350,400,403,425,455	08-1113	08-1113G
PONTIAC; 326,350P,389,400,428,455	08-1112	08-1112G
9-KEY	08-1112-9	

HEAVY DUTY .334 ROLLER SETS

- .334 Single roller chain
- 3-keyway heat treated steel crank sprocket with +/- 4 degrees cam adjustment
- Optional 9-keyway crank sprockets
- Cast iron cam sprocket

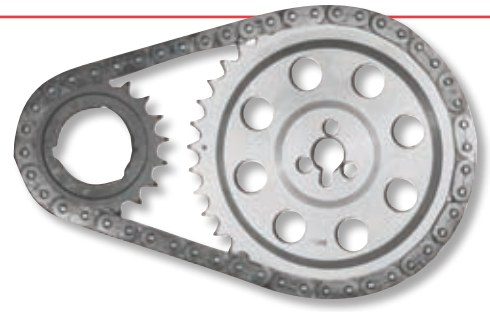

APPLICATION	OEM KIT #	PART #	PART #
CHEVROLET SMALL BLOCK			
1962-88 WITHOUT FACTORY ROLLER CAM	3055	08-3300	08-3300-9
1987-02 W/FACTORY ROLLER CAM	3104	08-3381	08-3381-9
CHEVROLET BIG BLOCK			
1991-96 366, 427, 454 - NON-FACTORY ROLLER CAM	3201	08-3399	08-3399-9
1996-99 454 VIN J	3137	08-3337	08-3337-9
LATE 1999-00 454 GEN VI VIN B , 2000 VIN J	3136	08-3336	08-3336-9
2001 496 VIN E,G	3258	08-3358	08-3358-9
2002-03 496 VIN E,G	3159	08-3359	08-3359-9
2004-07 496 VIN E,G	3163	08-3363	08-3363-9
CHEVROLET BIG BLOCK MARINE			
1991-98 454 NON-FACTORY ROLLER CAM	3201	08-3399	08-3399-9
1991-00 454, 502 W/FACTORY ROLLER CAM	3176	08-3376	08-3376-9
2001-05 454, 502 W/FACTORY ROLLER CAM	3180	08-3338	08-3338-9

HEAVY DUTY .200 ROLLER SETS

- .200 Double roller chain
- 3 Keyway crank sprocket with +/-4 degrees of cam adjustment
- Cast iron cam sprocket

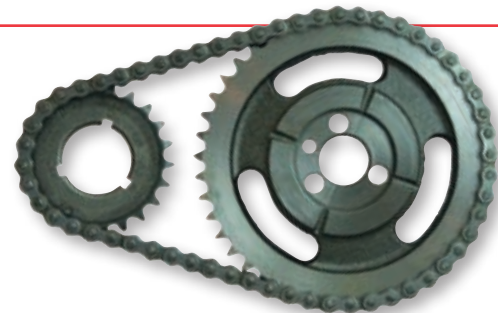

APPLICATION	OEM HD KIT #	PART #
CHEVROLET		
SMALL BLOCK 1955-86	3023	08-3023-3
- INCLUDES STEEL CRANKSHAFT SPROCKET		08-3023-3S
BIG BLOCK 1965-90	3024	08-3024-3
CHRYSLER		
V8 318, 340, 360, V6 239	3028	08-3028-3
383,400,426,440, HEMI - 3 BOLT CAM	3045	
383,400,426W, 440 - 1 BOLT CAM	3044	
FORD		
SMALL BLOCK, 1-PIECE FUEL PUMP ECCENTRIC, LATE 1965-EARLY 72		08-3054-3
SMALL BLOCK, 2-PIECE FUEL PUMP ECCENTRIC, LATE 1972-88	3057	08-3057-3
360,390,427,428 1-PIECE FUEL PUMP ECCENTRIC, 1963-EARLY 72	3029	
429, 460 W/FACTORY TDC TIMING, 1-PIECE FUEL PUMP ECCENTRIC	3079	
PONTIAC - 326,350,389,400,421,428,455	3043	

GEAR DRIVE TIMING SETS

- 8620 Carbonized steel gears
- Includes roller cam button, lock plate and bolts
- Timing adjusted with color coded dowel pin hole inserts
- Ford & Pontiac adjust timing +/- 4 degrees w/ 3 keyway crank sprocket

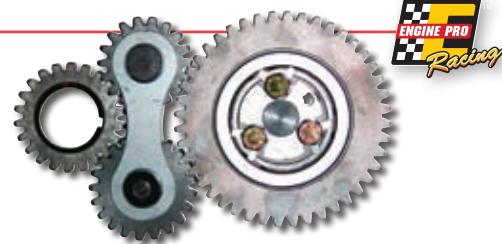

APPLICATION	NOISY	QUIET
CHEVROLET		
SMALL BLOCK 1955-86 W/THRUST BEARING	08-5100	08-5100Q
SMALL BLOCK 1987-93 FACTORY ROLLER CAM W/THRUST BEARING	08-5450	08-5450Q
BIG BLOCK 1965-90 W/THRUST BEARING	08-5410	08-5410Q
BIG BLOCK GEN VI (B,J) 1996-00 W/THRUST BEARING	08-5415	08-5415Q
CHRYSLER 383,400,426W-HEMI,440 3-BOLT CAM W/THRUST BEARING	08-5425	08-5425Q
FORD		
SMALL BLOCK 1963-02 W/BRONZE WASHER	08-5420	08-5420Q
351C, 351M, 400 W/BRONZE WASHER	08-5421	08-5421Q
429, 460 W/FACTORY TDC TIMING W/BRONZE WASHER	08-5430	08-5430Q
PONTIAC 350P,400,428,455 W/BRONZE WASHER	08-5412	08-5412Q

FORD V8 4.6L PERFORMANCE CAM AND CRANK SPROCKET KITS

- Contains all OEM replacement chains, tensioners and guides
- 2 cast iron cam sprockets with black oxide coating
- 2 cam spacers and 1 crank sprocket spacer
- 2 billet steel heat treated , 9-keyway crank sprockets



APPLICATION	PART #
FORD V8 4.6L (1996-02) VIN X, (1996-00) VIN W, 6, 9 (SPROCKETS ONLY)	08-7123A
FORD V8 4.6L (1999-02) VIN X (COMPLETE KIT)	08-7123
FORD V8 4.6L (1996-98) VIN X (1996-00) VIN W, 6, 9 (COMPLETE KIT)	08-7089

08-7123 COMPLETE KIT REPLACES C6123S 08-7123A SPROCKET KIT REPLACES C6089S AND C6123S SPROCKETS ONLY
 08-7089 COMPLETE KIT REPLACES C6089S KITS INCLUDE BLACK OXIDE COATED OEM CAM SPROCKETS S-764 AND S-766

FORD MODULAR V8 4.6L & 5.4L ADJUSTABLE CAM SPROCKET SET

- Billet steel two piece construction left and right bank cam sprockets
- Cam timing advance or retard up to 6 degrees
- Adjustment bolts are non magnetic stainless steel, includes adjustment tool

- Works with all OE replacement timing components
- Replaces cam sprockets S-764 and S-766

APPLICATION	PART #
TIMING SET	08-4764
LEFT BANK CAM SPROCKET	08-764A
RIGHT BANK CAM SPROCKET	08-766A



BELT DRIVE TIMING SET

- Adjustable timing cam gear up to 10 degrees advance or retard
- Heavy duty timing belt, thrust washers, seals and hardware included.

APPLICATION	PART #
CHEVROLET SMALL BLOCK 1955-88	08-5600

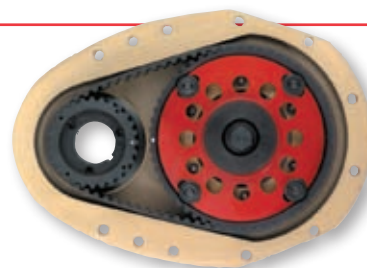

PERFORMANCE TIMING ACCESSORIES

CAM ROLLER THRUST BUTTON

Engine Pro's needle roller bearing thrust button keeps the camshaft from "walking" in the block. Use of thrust button is vital for accurate timing and to prevent premature timing chain wear.



APPLICATION	LENGTH	PART #
CHEVROLET SMALL BLOCK; 265 - 400	.795	08-8501
CHEVROLET BIG BLOCK; 396 - 454	.945	08-8511

- Machined alloy steel construction
- Roller needle bearing design
- Reduced friction, saves horsepower

SOLID ALUMINUM THRUST BUTTONS

- 6061T6 aluminum material
- Vibratory polished

APPLICATION	LENGTH	PART #
CHEVROLET SMALL BLOCK; 265-400 (LATE SHORT)	.690	08-8551
CHEVROLET SMALL BLOCK; 265-400 (EARLY LONG)	.830	08-8561
CHEVROLET BIG BLOCK; 396-454 (ALL)	.945	08-8512



CAM LOCK PLATES

Our lock plate is low cost insurance against camshaft bolts backing out under any RPM or load condition.

- Bendable locking tabs
- Black oxide coating
- Grade 8 bolts

APPLICATION	PART #
CHEVROLET SMALL & BIG BLOCK V8 & 90 DEGREE V6	08-8502
CHEVROLET LS GEN III & IV - 3 BOLT DESIGN	08-8503



CAMSHAFT DEGREE BUSHING SET

- Helps in precisely positioning camshaft
- Color coded
- Requires a 13/32" drill

APPLICATION	LENGTH	PART #
CHEVROLET SMALL & BIG BLOCK V8 AND CHRYSLER HEMI 3-BOLT	SET OF 5 BUSHINGS (ONE EACH 0°, 2°, 4°, 6°, 8°)	08-9760



CAMSHAFT THRUST PLATE

APPLICATION	PART #
CHEVROLET SMALL & BIG BLOCK - 3.90" TIP-TO-TIP	08-7000
CHEVROLET LS - WITH COUNTERSUNK BOLT HOLES	08-7016TPK*
FORD SMALL BLOCK - USE WITH SETS # 08-2003T-9, 08-2023T-9 & 08-4751	08-7820TPK*
PONTIAC V8	08-7301



*Includes: countersunk thrust plate with 2 screws

TIMING TENSIONER AND DAMPER

Precision engineered and manufactured from high-quality materials for consistent durable wear.

APPLICATION		PART #
CHRYSLER V8; 318, 340, 360 V8, 236 V6	TENSIONER	08-9428*
	TENSIONER	91049
CHEVROLET LS; GM 2007-17		
CHEVROLET LS; GM 2004-09	DAMPER	9617

*Replaces the cam thrust plate, works with all roller timing chains, interchange with Chrysler performance part # P5007709.



BRONZE DISTRIBUTOR GEARS

- AMPCO 45 extruded aluminum bronze material
- Can be used with cast iron, austemper steel and steel camshaft material
- Wear resistant, held to OEM tolerances
- Made in USA

APPLICATION	SHAFT DIA.	PART #
CHEVROLET SMALL & BIG BLOCK V8	.491	100-4910
CHEVROLET SMALL & BIG BLOCK V8	.501	100-5010

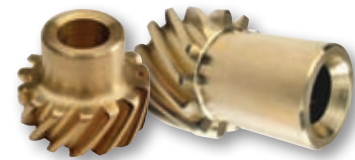

MELONITE DISTRIBUTOR GEARS

- Metal is coated with melonite - not composite plastic
- Wear resistant under high RPM conditions
- For use with cast Iron camshafts only, not steel
- More durable than bronze gears when used with cast iron camshafts
- Made in USA

APPLICATION	SHAFT DIA.	PART #
CHEVROLET SMALL & BIG BLOCK V8	.491	100-1000
CHEVROLET SMALL & BIG BLOCK V8	.501	100-1010



LS TIMING COVER SETS

Sets include aluminum timing cover housing, seal, gasket and bolts.

APPLICATION	OEM COVER #	PART #
CHEVROLET		
LS1 AND LS6 WITHOUT CAM SENSOR HOLE	12561243	08-8243K
LS2 AND LS3 WITH SENSOR HOLE; W/O VVT	12633906	08-8906K
GEN IV LS WITH SENSOR HOLE FOR USE WHEN ELIMINATING VVT		08-8906KSW
INCLUDES TIMING COVER, CAM SENSOR, WIRE HARNESS, BOLTS, AND GASKET		

08-8906KSW

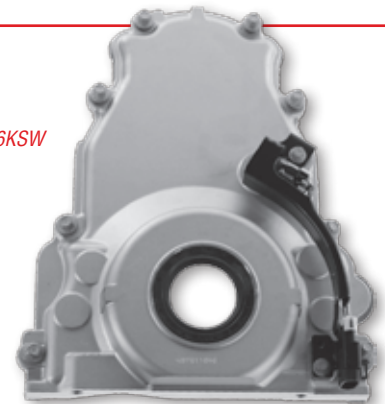

PERFORMANCE STEEL AND ALUMINUM TIMING COVERS

STEEL

- Made in the U.S.A.
- Black powder coating
- Heavy gauge steel
- Early style design
- Precision stamped for proper fit
- Reinforcing ribs for use with cam button
- Die-stamped Engine Pro Logo



08-8001

ALUMINUM

- Stainless steel socket head cap screws included
- Rigid lightweight one piece design
- Polished die cast aluminum
- Cast-In Engine Pro name



08-8002 - 08-8003

APPLICATION	DESIGN	PART #
CHEVROLET		
SMALL BLOCK 1965-90	STEEL	08-8001
	ALUMINUM	08-8002
BIG BLOCK 1965-90	ALUMINUM	08-8003

TIMING COVER STUD KIT

Included in this kit are ten 170,000 PSI black oxidized studs and ten zinc coated undersized head nuts. This kit will work with both stamped and aluminum timing covers.

APPLICATION	PART #
CHEVROLET SMALL BLOCK & BIG BLOCK THRU 1995	29-4006



ADJUSTABLE BILLET TIMING POINTERS

APPLICATION	BALANCER DIA.	PART #
CHEVROLET SMALL BLOCK	6 1/8"	14-61900
	6 1/4"	14-61905
	6 3/8"	14-61907
	6 3/4"	14-61910
	7 1/4"	14-61911
	8"	14-61915
CHEVROLET BIG BLOCK	6 1/4"	14-61918
	7"	14-61919
	7 1/4"	14-61920
	8"	14-61922
FORD SMALL BLOCK 302-351	6 1/4 TO 6.700"	14-61930



- Machined from high quality billet aluminum
- Anodized black for corrosion resistance
- 4 degrees of timing adjustment
- Stainless steel mounting hardware
- Minimum clearance between pointer and harmonic balancer improves timing accuracy

4340 STEEL HARMONIC BALANCER BOLTS

APPLICATION	UHL	PART #
CHEVROLET SMALL BLOCK WITH 7/16" NF THREAD	1 7/8"	06-1200
CHEVROLET BIG BLOCK WITH 1/2" NF THREAD	1 5/16"	06-1201

- 1" hex head w/Integral washer
- 4340 billet steel construction
- Rolled threads
- Black oxide finish



ENGINE PRO PERFORMANCE HARMONIC BALANCERS



STREET PERFORMANCE BALANCERS are the perfect choice for race classes that require an O.E. type balancer. They are also an economical choice for high powered street engines.

SFI RACE SERIES BALANCERS bring the advantage of bonded balancers to high revving race and street/race applications where an SFI approval is required. The steel inertia ring positively protects against forward and backward movement of ten times the force of O.E. non-bonded balancers



APPLICATION	OUTSIDE DIA.	DEPTH OVERALL	RING WIDTH	BALANCE	STREET PERFORMANCE SERIES		SFI RACE SERIES		
					WT	PART #	WT	PART #	
CHEVROLET SMALL BLOCK									
283 - 307 CID 6 1/4" STREET STOCK SPEEDWAY LIGHT WEIGHT	6.10	2.32	1.34	NEUTRAL	4.6	PB1012-ST	5.8	PB1012-SS	
283 - 350 SMALL BLOCK V-8 7"	6.75	2.36	1.32	NEUTRAL	7.9	PB2221-ST	8.1	PB2221-SS	
283 - 350 SMALL BLOCK V-8 8"	8.00	2.33	1.60	NEUTRAL	10.4	PB1046-ST	11.2	PB1046-SS	
400 SMALL BLOCK V-8 8"	8.00	2.33	1.60	C/W RING	7.9	PB1050-ST	10.7	PB1050-SS	
350 (5.7L) LT1 1993-97 CRANK FLANGE MOUNT SERP. BELT	7.50	N/A	1.28	NEUTRAL		PB1481-ST	8.4	PB1481-SS	
STEEL CRANK FLANGE (SHORT) F-BODY 93-95, CORVETTE 92-95	LENGTH 3.516 USE WITH PB1481-SS & PBU1481-SS								FHS1481-SS
CHEVROLET BIG BLOCK									
396 - 427 BIG BLOCK V-8 8"	8.00	2.68	1.95	NEUTRAL	13.2	PB1211-ST	15.4	PB1211-SS	
454 BIG BLOCK V-8 8"	8.00	2.68	1.95	C/W HUB	15.1	PB1018-ST	16.8	PB1018-SS	
396 - 454 BIG BLOCK LIGHT WEIGHT NEUTRAL BALANCE	7.10	2.68	1.42	NEUTRAL	8.9	PB1019-ST	9.7	PB1019-SS	
CHEVROLET LS									
LS1 GEN III ALL ALLOY 5.7L V-8 CAMARO & FIREBIRD SERP. BELT	7.50	3.66	2.22	NEUTRAL		PB1480-ST	11.2	PB1480-SS	
LS6 5.7L, LS2 6.0L, LS3 6.2L V-8 SERP BELT CORVETTE, SSR	7.50	2.83	2.42	NEUTRAL			8.6	PB1117-SS	
CHRYSLER									
318, 340 SMALL BLOCK INTERNAL BALANCED	7.11	2.56	1.20	NEUTRAL		PB1004-ST	9.4	PB1004-SS	
440 BIG BLOCK (WITH STEEL CRANKSHAFT)	7.24	2.56	1.20	NEUTRAL		PB1112-ST	9.4	PB1112-SS	
FORD V-8									
302, 351 CLEVELAND V-8	6.50	3.50	1.39	C/W HUB	9.3	PB1082-ST	10.9	PB1082-SS	
289, 302 WINDSOR V-8 3 BOLT (COUNTERSUNK PULLEY LOCATION)	6.33	3.00	0.77	C/W HUB	6.6	PB1008-ST			
302, 351 WINDSOR 3 BOLT (RAISED PULLEY LOCATION) 280Z.	6.50	3.18	1.39	C/W HUB	9.2	PB1203-ST	10.9	PB1203-SS	
302, 351 WINDSOR 3 BOLT (COUNTERSUNK PULLEY LOCATION) 280Z.	6.50	3.18	1.39	C/W HUB	9.1	PB1009-ST	10.9	PB1009-SS	
302, 351 WINDSOR V-8 4 BOLT (RAISED PULLEY LOCATION) 280Z.	6.50	4.09	1.25	C/W HUB	10.1	PB1060-ST	11.4	PB1060-SS	
302 WINDSOR V-8 EFI V-8 4 BOLT 500Z.	6.40	4.13	1.57	C/W HUB	9.1	PB1084-ST	10.9	PB1084-SS	
5.0L EFI WINDSOR V-8 WITH FACTORY CRANK TRIGGER	6.38	4.05	1.48	C/W RING	9.6	PB1463-ST			
302, 351 WINDSOR V-8 NEUTRAL BALANCE LIGHTWEIGHT 4 BOLT	6.37	4.13	1.57	NEUTRAL			8.0	PB1086-SS	
390 BIG BLOCK FE V-8 INTERNAL BALANCE	7.10	5.74	1.10	NEUTRAL	7.7	PB1111-ST	8.9	PB1111-SS	
460 BIG BLOCK V-8 INTERNAL BALANCE	6.62	1.62	1.37	NEUTRAL		PB1210-ST	9.6	PB1210-SS	
NOTE: Externally balanced 460 must use factory winged counterweight									
PONTIAC									
287 TO 455 CID V-8	6.79	3.24	1.26	NEUTRAL	6.8	PB1056-ST	10.4	PB1056-SS	
5.7L LS1, 6.0L LS2 V-8 SERP BELT GTO	7.50	2.25	1.37	NEUTRAL			11.2	PB1480-SS	
6.0L L98, 6.2L LS3 V-8 SERP BELT G8	7.50	2.83	2.42	NEUTRAL			8.55	PB1117-SS	

OEM HARMONIC BALANCER BOLTS FOR LS CHEVROLET

- Torque to yield design
- Produced by OEM supplier

APPLICATION	OEM #	PART #
GEN III & IV 4.8 - 6.2L ENGINES EXCEPT DRY SUMP OILING	12557840	06-7840
6.2 & 7.0L CAMARO & CORVETTE DRY SUMP OILING ONLY	11570163	06-0163



NITRO BLACK COATED PERFORMANCE ENGINE BEARINGS



FEATURES

Calico CT-1 Dry Film Lubricant Coating

PROCESS

CT-1 is applied as a spray process with a typical coating thickness for engine bearings of 0.00025" to 0.00030" inch (6 to 7.5) microns.

ADVANTAGES

- Provides intermittent dry lubrication
- Not affected by dust or dirt
- Low coefficient of friction
- Increases load carrying capacity
- Thin coating to accommodate assembly constraints
- Chemical resistance
- Corrosion protection
- Reduced friction and drag resulting in decreased parasitic load

EMBEDDED ABILITY

CT-1 coated bearings have excellent embedded ability characteristics, allowing debris contaminants to embed in the bearing, avoiding damage to the crank.

INCREASED LOAD CARRYING CAPACITY

Under normal conditions performance bearing overlays withstand 12,000psi. CT-1 coated bearings increase this load capacity to 180,000psi.

OIL TEMPERATURES

CT-1 coated bearings have shown a reduction in oil temperatures as much as 150F - 200F.

STARVATION

CT-1 coated engine bearings provide a dry film lubricant that protects against intermediate oil starvation.



APPLICATION	ROD BEARING PART #	MAIN BEARING PART #	OIL CLEARANCE
CHEVROLET			
SMALL BLOCK LARGE JOURNAL	11-663HC	12-909HC	STD
	11-663HXC	12-909HXC	+0.001
SMALL BLOCK SMALL JOURNAL	11-745HC	12-429HC	STD
	11-745HXC	12-429HXC	+0.001
SMALL BLOCK GEN III & IV LS	11-663HC	12-2199HC	STD
	11-663HXC	12-2199HXC	+0.001
BIG BLOCK	11-743HC	12-829HC	STD
	11-743HXC	12-829HXC	+0.001
WITH DOWEL HOLE	11-743HDC		STD
	11-743HXDC		+0.001
FORD			
221, 255, 260, 289, 302 C.I.D.	11-634HC	12-590HC	STD
	11-634HXC	12-590HXC	+0.001
351C AND SVO 2.750" MAINS	11-927HC	12-1010HC	STD
		12-1010HXC	+0.001
429, 460 C.I.D.	11-818HC	12-1039HC	STD
SUBARU			
52MM ROD BEARINGS	11-1657HC	12-8309HC	STD
THRUST BEARING IN #5 POSITION	11-1657HXC	12-8309HXC	+0.001
CUSTOM PERFORMANCE 2.015" HOUSING BORE			
1.8885 - 1.8890 SHAFT	11-1663HC		STD
DIAMETER/.792" LONG	11-1663HXC		+0.001

PERFORMANCE ENGINE BEARINGS



Engine Pro Performance Series bearings deliver a unique and desirable combination of strength and flexibility, two ways!



ALL OUR PERFORMANCE SERIES BEARINGS FEATURE

- Tri-metal material
- Oversized chamfers for large radius fillets
- Mains are 3/4 grooved for optimum oil supply and increased bearing surface area for better load carrying capability.
- Hardened backing material with greater fatigue strength

RACE SERIES

ADDED FEATURES:

- High crush and no flash plating to improve seating
- Medium eccentricity to maintain uniform oil clearance
- Thinner, high strength overlay to increase fatigue strength
- Wall tolerance +/- .00015" to maintain accurate clearances

E15000 SERIES

ADDED FEATURES:

- Higher amount of crush height for maximum fit and retention
- More eccentricity in rod bearing to avoid contact and increase oil flow
- 15,000 psi load carrying capacity
- Patented profile on thrust bearing face doubles load capacity

APPLICATION		ROD BEARING PART #	MAIN BEARING PART #	OIL CLEARANCE	ROD BEARING PART #	MAIN BEARING PART #	OIL CLEARANCE
CHEVROLET	SMALL BLOCK LARGE JOURNAL	11-663H*	12-909H*	STD	11E-663H8*	12E-909H*	STD
		11-663HD#		STD	11E-663HD8#		STD
		11-663HX	12-909HX	+0.001	11E-663HX8	12E-909HX	+0.001
		11-663HXD#		+0.001	11E-663HXD8#		+0.001
	SMALL BLOCK SMALL JOURNAL	11-745H	12-429H	STD	11E-745H8	12E-429H	STD
		11-745HD #		STD	11E-745HD8#		STD
		11-745HX	12-429HX	+0.001	11E-745HX8	12E-429HX	+0.001
		11-745HXD#		+0.001	11E-745HXD8#		+0.001
	SMALL BLOCK 400 C.I.D.	11-663H*	12-1038H	STD	11E-663H8*	12E-1038H	STD
		11-663HD#		STD	11E-663HD8#		STD
		11-663HX	12-1038HX	+0.001	11E-663HX8	12E-1038HX	+0.001
		11-663HXD #		+0.001	11E-663HXD8#		+0.001
	SMALL BLOCK GEN III & IV LS	11-663H*	12-2199H	STD	11E-663H8*	12E-2199H	STD
		11-663HD #		STD	11E-663HD8#		STD
		11-663HX	12-2199HX	+0.001	11E-663HX8	12E-2199HX	+0.001
		11-663HXD #		+0.001	11E-663HXD8#		+0.001
	SMALL BLOCK GEN V 5.3L, 6.2L	11-7281H	12-2339H	STD			
		11-7281HX	12-2339HX	+0.001			
	BIG BLOCK	11-743H#	12-829H*	STD	11E-743H8*	12E-829H*	STD
		11-743HD#		STD	11E-743HD8#		STD
	11-743HX*	12-829HX	+0.001	11E-743HX8*	12E-829HX	+0.001	
	11-743HXD #		+0.001	11E-743HXD8#		+0.001	
CHRYSLER	273, 318, 340, 360 C.I.D.	11-481H		STD	11E-481H8		STD
		11-481HX		+0.001	11E-481HX8		+0.001
	345 (5.7L), 370 (6.1L) LATE HEMI	11-1808H	12-2220H^	STD			
		11-1808HX	12-2220HX^	+0.001			
	361, 383, 400, 426, 440 C.I.D.	11-527HD#		STD	11E-527HD8#		STD
		11-527HXD#		+0.001			

* Crank saver sizes (.009", .011", .019", .021") # HD and HXD bearings have dowel hole. IMPORTANT NOTE: Bearings are available in standard size and various undersizes. Please refer to price list for specific undersizes by part number. All bearings are priced and sold in sets. ^ Requires 13-611S thrust washers.

PERFORMANCE ENGINE BEARINGS CONTINUED



Engine Pro Performance Series bearings deliver a unique and desirable combination of strength and flexibility, two ways!

		RACE SERIES			E15000 SERIES		
APPLICATION		ROD BEARING PART #	MAIN BEARING PART #	OIL CLEARANCE	ROD BEARING PART #	MAIN BEARING PART #	OIL CLEARANCE
FORD	221, 255, 260, 289, 302 C.I.D.	11-634H*	12-590H*	STD	11E-634H8*	12E-590H*	STD
		11-634HD #	12-590H *	STD	11E-634HX8	12E-590HX	+0.01
	221, 255, 260, 289, 302 C.I.D.	11-634HX	12-590HX	+0.01			
		11-634HDX #	12-590HX	+0.01			
	281 C.I.D. (4.6L), 330 C.I.D. (5.4L)	11-1442H	12-2202H	STD	11E-1442H8	12E-2202	STD
		11-1442HX	12-2202HX	+0.01	11E-1442HX8	12E-2202HX	+0.01
	5.0L COYOTE DOHC 2011-17	11-1442H	12-2292H	STD	11E-1442H8		STD
		11-1442HX	12-2292HX	+0.01	11E-1442HX8		+0.01
	351C & SVO 2.750" MAINS	11-927H	12-1010H	STD		12E-1010H	STD
			12-1010HX	+0.01		12E-1010HX	+0.01
	351M, 400 1977-ON	11-927H	12-1432H	STD		12E-1432H	STD
			12-1432HX	+0.01		12E-1432HX	+0.01
	351W 1977-ON		12-1432H	STD	11E-831H8	12E-1432H	STD
			12-1432HX	+0.01		12E-1432HX	+0.01
429, 460 C.I.D.	11-818H	12-1039H	STD	11E-818H8	12E-1039H	STD	
		12-1039HX	+0.01		12E-1039HX	+0.01	
MITSUBISHI	4G63/4G64	11-1185H	12-1186H**	STD			
	6/92-99	11-1185HX	12-1186HX**	+0.01			
	4G63/4G64	11-1185H	12-1219H***	STD			
	97-99	11-1185HX	12-1219HX***	+0.01			
SUBARU	52MM ROD BEARINGS.	11-1657H	12-8309H	STD			
	THRUST BEARING IN #5 POSITION	11-1657HX	12-8309HX	+0.01			
CUSTOM 2.015" HOUSING BORE	1.8885 - 1.8890 SHAFT	11-1663H		STD	11E-1663H8		STD
	DIA. / .792" LONG	11-1663HX		+0.01	11E-1663HX8		+0.01
	1.8885 - 1.8890 SHAFT	11-1665HD #		STD			
	DIA. / .896" LONG	11-1665HDX #		+0.01			

*Crank saver sizes (.009", .011", .019", .021") # HD and HXD bearings have dowel hole. IMPORTANT NOTE: Bearings are available in standard size and various undersizes. Please refer to price list for specific undersizes by part number. All bearings are priced and sold in sets.

** With intregal thrust. ***Requires 13-677S thrust washers.



H-BEAM CONNECTING RODS

- Forged from 4340 steel
- Magnafluxed • Heat treated
- Stress relieved • Shot peened • Sonic tested
- Weight balanced + or - 1.5 grams
- Three levels of bolts

- ARP 8740 cap screw • ARP 2000 • ARP L19 • Bronze bushed pin bores
- ARP moly bolt lube included • Finished machined in the USA



8740 CHROMOLY:
Until the development of today's modern alloys, chromoly was popularly considered a high strength material. Now viewed as only moderate strength, 8740 chromoly is seen as a good tough steel, with adequate fatigue properties for most racing applications, but only if the threads are rolled after heat treatment, as is the standard ARP production practice. Typically, chromoly is classified as a quench and temper steel, that can be heat-treated to deliver tensile strengths between 180,000 and 210,000 PSI.

ARP2000®:
An exclusive, hybrid-alloy developed to deliver superior strength and better fatigue properties. While 8740 and ARP2000 share similar characteristics – ARP2000 is capable of achieving clamp loads in the 215,000-220,000 PSI range. ARP2000 is used widely in short track and drag racing as an upgrade from 8740 chromoly in both steel and aluminum rods. Stress corrosion and hydrogen embrittlement are typically not a problem, providing care is taken during installation.

L19:
Premium steel processed to deliver superior strength and fatigue properties. L19 is a very high strength material compared to 8740 and ARP2000. Capable of clamp delivering loads in the 230,000-260,000 PSI range. Primarily used in short track and drag racing applications where inertia loads exceed the capability of ARP2000. L19 requires special care during manufacturing to avoid hydrogen embrittlement. This material is easily contaminated and subject to stress corrosion. It must be kept well-oiled and not exposed to moisture.

APPLICATION	LENGTH	ROD JOURNAL SIZE	PIN BORE	WEIGHT	PART #	PART #	PART #
CHEVROLET SMALL BLOCK	5.700	2.100	.928	632	10-1000-8	10-1100-8	10-1200-8
	5.700	2.000	.928	640	10-1001-8	10-1101-8	10-1201-8
	6.000	2.100	.928	642	10-1002-8	10-1102-8	10-1202-8
	6.000	2.000	.928	660	10-1003-8	10-1103-8	10-1203-8
	6.125	2.100	.928	720	10-1004-8	10-1104-8	10-1204-8
	6.200	2.100	.928	650	10-1020-8	10-1120-8	10-1220-8
CHEVROLET GEN III & IV LS NO OFFSET	6.125	2.100	.928	603		10-1108-8	
	6.125	2.100	.928	720		10-1118-8	10-1218-8
CHEVROLET BIG BLOCK	6.135	2.200	.991	790	10-1005-8	10-1105-8	10-1205-8
	6.385	2.200	.991	809	10-1006-8	10-1106-8	10-1206-8
	6.535	2.200	.991	821	10-1007-8	10-1107-8	10-1207-8
	6.700	2.200	.991	815	10-1025-8	10-1125-8	10-1225-8
	6.800	2.200	.991	820	10-1026-8	10-1126-8	10-1226-8
FORD SMALL BLOCK	5.400	2.123	.913	604	10-1009-8	10-1109-8	10-1209-8
	5.400	2.100	.928	604	10-1010-8	10-1110-8	10-1210-8
	5.400	2.123	.928	604	10-1011-8	10-1111-8	10-1211-8
FORD MODULAR 4.6	5.933	2.086	.867	602		10-1112-8	

ARP ROD BOLTS

DESCRIPTION	PART #
3/8"X1.500" ARP2000 BOLT	4AJ1.500-2SU
7/16"X1.600" 8740 BOLT	4AP1.601-1LU
7/16"X1.600" ARP 2000 BOLT	4AP1.601-2LU
7/16"X1.600" L19 BOLT	5AP1.601-6SLU



ENGINE PRO BOLT BOOTS

DESCRIPTION	PART#
BOLT BOOTS, BAG OF 50 PIECES	BB1-50



- Protect crankshaft journal surfaces during assembly
- Red plastic with 'ENGINE PRO' Logo

NITRO BLACK SS SERIES STAINLESS STEEL NITRIDED RACE RINGS

- Designed for late model muscle-LS Chevrolet & Chrysler hemi engines
- Extremely durable sets with features only found in Nitro Black series



RING DESIGN

Top Ring- Nitrided stainless steel with a barrel face

Second Ring- Ductile iron Napier profile designed optimum durability and oil scraping ability under the most severe performance conditions

Oil Ring- Patented Flex-vent for maximum oil control



Race-tested and proven to deliver higher output for super performance engines

1.2 - 1.2 - 3.0 MM LOW TENSION

BORE SIZE	SET #	BORE SIZE	SET #
3.780	43SS9030 STD	4.045	43SS9045 .045
3.785	43SS9030 .005	4.050	43SS9045 .050
3.790	43SS9030 .010	4.055	43SS9045 .055
3.800	43SS9030 .020	4.060	43SS9045 .060
3.810	43SS9030 .030	4.065	43SS9045 .065
3.820	43SS9030 .040	4.070	43SS9045 .070
3.898	43SS9035 STD	4.075	43SS9045 .075
3.905	43SS9035 .007	4.080	43SS9045 .080
3.917	43SS9040 STD	4.085	43SS9045 .085
3.927	43SS9040 .010	4.090	43SS9045 .090
3.937	43SS9040 .020	4.095	43SS9045 .095
4.000	43SS9045 STD	4.100	43SS9045 .100
4.005	43SS9045 .005	4.120	43SS9045 .120
4.010	43SS9045 .010	4.125	43SS9050 STD
4.015	43SS9045 .015	4.135	43SS9050 .010
4.020	43SS9045 .020	4.145	43SS9050 .020
4.025	43SS9045 .025	4.155	43SS9050 .030
4.030	43SS9045 .030	4.165	43SS9050 .040
4.035	43SS9045 .035	4.185	43SS9050 .060
4.040	43SS9045 .040		

1.2 - 1.5 - 3.0 MM LOW TENSION

BORE SIZE	SET #
3.898	43SS9055 STD
3.905	43SS9055 .007
3.917	43SS9060 STD
3.927	43SS9060 .010
3.937	43SS9060 .020
4.000	43SS9065 STD
4.005	43SS9065 .005
4.025	43SS9065 .025
4.030	43SS9065 .030
4.035	43SS9065 .035
4.040	43SS9065 .040
4.045	43SS9065 .045
4.055	43SS9065 .055
4.060	43SS9065 .060
4.065	43SS9065 .065
4.070	43SS9065 .070
4.080	43SS9065 .080
4.100	43SS9065 .100
4.120	43SS9065 .120

STEEL MOLY RACE RINGS WITH NAPIER SECOND RING

TOP RING FEATURES

- Impact resistant plasma moly alloy
- Designed for most demanding high compression applications
- Reduced side wear and extended life
- Alloy steel
- High stress and high temperature conditions

RING DESIGN TOP RING: STEEL, PLASMA MOLY
 SECOND RING: DUCTILE IRON NAPIER | OIL RING: FLEX-VENTRING: FLEX-VENT

1.5 - 1.5 - 3.0 MM LOW TENSION

BORE SIZE	SET #
3.780	43SM8531 STD
3.785	43SM8531 .005
3.795	43SM8531 .015
3.805	43SM8531 .025
3.815	43SM8531 .035
3.825	43SM8531 .045
3.845	43SM8531 .065
3.898	43SM8555 STD
3.905	43SM8555 .007
3.917	43SM8560 STD
3.927	43SM8560 .010
3.937	43SM8560 .020
4.000	43SM8565 STD
4.005	43SM8565 .005
4.025	43SM8565 .025
4.030	43SM8565 .030
4.080	43SS9065 .080
4.100	43SS9065 .100
4.120	43SS9065 .120

BORE SIZE	SET #
4.035	43SM8565 .035
4.040	43SM8565 .040
4.045	43SM8565 .045
4.055	43SM8565 .055
4.060	43SM8565 .060
4.065	43SM8565 .065
4.070	43SM8565 .070
4.080	43SM8565 .080
4.100	43SM8565 .100
4.120	43SM8565 .120

.043 - 1/16" - 3.0MM LOW TENSION

BORE SIZE	SET #
4.5000	43SM8592 STD
4.5050	43SM8592 .005
4.5350	43SM8592 .035
4.5650	43SM8592 .065

.043 - .043 - 3.0MM LOW TENSION

BORE SIZE	SET #
4.000	43SM8556 STD
4.005	43SM8556 .005
4.025	43SM8556 .025
4.035	43SM8556 .035
4.045	43SM8556 .045
4.055	43SM8556 .055
4.060	43SM8556 .060
4.065	43SM8556 .065
4.070	43SM8556 .070
4.250	43SM5597 STD
4.285	43SM5597 .035
4.500	43SM8582 STD
4.505	43SM8582 .005
4.535	43SM8582 .035
4.605	43SM8582 .105
4.630	43SM8582 .130

STEEL MOLY RACE RINGS

TOP RING FEATURES

- Impact resistant plasma moly alloy
- Designed for most demanding high compression applications
- Reduced side wear and extended life
- Alloy steel
- High stress and high temperature conditions

RING DESIGN TOP RING: STEEL, PLASMA MOLY
 SECOND RING: CAST IRON, REVERSE TORSIONAL TWIST | OIL RING: FLEX-VENT

.043- 1/16" - 3/16" STD. TENSION

BORE SIZE	SET #
4.0000	43SM8527 STD
4.0050	43SM8527 .005
4.0250	43SM8527 .025
4.0350	43SM8527 .035
4.0450	43SM8527 .045
4.0650	43SM8527 .065
4.0850	43SM8527 .080
4.1250	43SM8547 STD
4.1300	43SM8547 .005
4.1450	43SM8547 .020
4.1500	43SM8547 .025
4.1550	43SM8547 .030
4.1600	43SM8547 .035
4.1650	43SM8547 .040
4.1700	43SM8547 .045
4.1850	43SM8547 .060
4.2500	43SM8567 STD

.043 - .043 - 3.0MM LOW TENSION

BORE SIZE	SET #
4.000	43SM5587 STD
4.030	43SM5587 .030
4.035	43SM5587 .035
4.040	43SM5587 .040
4.045	43SM5587 .045
4.060	43SM5587 .060
4.065	43SM5587 .065
4.125	43SM5593 STD
4.130	43SM5593 .005
4.140	43SM5593 .015
4.145	43SM5593 .020
4.150	43SM5593 .025
4.160	43SM5593 .035
4.165	43SM5593 .040
4.185	43SM5593 .060

.043 - 1/16" - 3/16" LOW TENSION

BORE SIZE	SET #
4.0000	43SM8537 STD
4.0050	43SM8537 .005
4.0350	43SM8537 .035
4.0450	43SM8537 .045
4.0650	43SM8537 .065
4.0850	43SM8537 .080
4.1250	43SM8557 STD
4.1300	43SM8557 .005
4.1550	43SM8557 .030
4.1600	43SM8557 .035
4.1650	43SM8557 .040
4.1700	43SM8557 .045
4.1850	43SM8557 .060
4.2500	43SM8577 STD

1.5 - 1.5 - 3.0MM LOW TENSION

BORE SIZE	SET #
3.5520	43SN5582 .005*
3.5720	43SN5582 .025*
3.5820	43SN5582 .035*
3.5920	43SN5582 .045*

*Nitrided steel top groove.

PREMIUM DUCTILE PLASMA MOLY TOP - NAPIER SECOND RING

TOP RING FEATURES

- Impact resistant plasma moly alloy
- Reduced side wear and extended life
- Designed for the most demanding high compression applications
- Designed for high stress and high temperature conditions

RING DESIGN TOP RING: DUCTILE IRON, PLASMA MOLY
SECOND RING: DUCTILE IRON, NAPIER | OIL RING: FLEX-VENT

SECOND RING NAPIER DESIGN FEATURES:

- Optimal durability and oil scraping ability under most severe conditions
- Measurably Improved Horsepower

OIL RING DESIGN FEATURES:

- Flex-Vent design minimizes friction
- Improved flexibility and high RPM oil control
- Thin wall contact allows for quick break-in

1/16" - 1/16" - 3/16" STD. TENSION

BORE SIZE	SET #
4.0000	43M8542 STD
4.0050	43M8542 .005
4.0300	43M8542 .030
4.0350	43M8542 .035
4.0400	43M8542 .040
4.0450	43M8542 .045
4.0600	43M8542 .060
4.0650	43M8542 .065
4.1250	43M8552 STD
4.1300	43M8552 .005
4.1350	43M8552 .010
4.1450	43M8552 .020
4.1500	43M8552 .025
4.1550	43M8552 .030
4.1600	43M8552 .035
4.1650	43M8552 .040
4.1700	43M8552 .045
4.1850	43M8552 .060
4.1900	43M8552 .065
4.2500	43M8562 STD
4.2550	43M8562 .005
4.2800	43M8562 .030
4.2850	43M8562 .035
4.2900	43M8562 .040
4.3100	43M8562 .060
4.3150	43M8562 .650
4.3750	43M8562 .125
4.5000	43M8588 STD
4.5050	43M8588 .005
4.5350	43M8588 .035
4.5450	43M8588 .045
4.5650	43M8588 .065

1.5 - 1.5 - 3.0MM LOW TENSION

BORE SIZE	SET #
4.0000	43M8521 STD
4.0050	43M8521 .005
4.0350	43M8521 .035
4.0450	43M8521 .045
4.0650	43M8521 .065
4.1250	43M8505 STD
4.1300	43M8505 .005
4.1600	43M8505 .035
4.1700	43M8505 .045
4.1900	43M8505 .065

1/16"-1/16"-1/8" STD. TENSION

BORE SIZE	SET #
4.0000	43M8571 STD
4.0050	43M8571 .005
4.0300	43M8571 .030
4.0350	43M8571 .035
4.0450	43M8571 .045
4.0650	43M8571 .065

1/16" - 1/16" - 3/16" LOW TENSION

BORE SIZE	SET #
4.0000	43M8543 STD
4.0050	43M8543 .005
4.0300	43M8543 .030
4.0350	43M8543 .035
4.0000	43M8543 .040
4.04500	43M8543 .045
4.0600	43M8543 .060
4.0650	43M8543 .065
4.1250	43M8543 STD
4.1300	43M8559 .005
4.1550	43M8559 .030
4.1600	43M8559 .035
4.1650	43M8559 .040
4.1700	43M8559 .045
4.1850	43M8559 .060
4.1900	43M8559 .065
4.5000	43M8559 STD
4.5050	43M8594 .005
4.5350	43M8594 .035
4.5450	43M8594 .045

DUCTILE CHROME BARREL FACE TOP RINGS

RING DESIGN

TOP RING: DUCTILE CHROME BARREL FACED

SECOND RING: CAST IRON, REVERSE TORSIONAL TWIST

OIL RING: FLEX-VENT

THESE ARE ALL 4 CYLINDER SETS

1.5-1.5-3.0MM LOW TENSION

BORE SIZE	SET #
3.2680	43C5573 STD
3.2780	43C5573 .010
3.2880	43C5573 .020
3.2980	43C5573 .030
3.3080	43C5573 .040
3.3280	43C5573 .060

SNH SERIES

Same as Nitro Black SS Series with the addition of Nitride Flex-Vent® oil ring for 4-cylinder import performance applications.

RING DESIGN TOP RING: STAINLESS STEEL NITRIDE | SECOND: DUCTILE NAPIER | OIL: NITRIDE FLEX-VENT
THESE ARE ALL 4 CYLINDER SETS

1.0 - 1.2 - 2.8MM LOW TENSION

BORE SIZE	SET #
3.189	43SNH08100
3.209	43SNH08150
3.229	43SNH08200
3.307	43SNH08400
3.327	43SNH08450
3.346	43SNH08500

1.0 - 1.2 - 2.8MM LOW TENSION

BORE SIZE	SET #
3.366	43SNH08550
3.386	43SNH08600
3.405	43SNH08650
3.425	43SNH08700
3.445	43SNH08750
3.465	43SNH08800



PREMIUM DUCTILE PLASMA MOLY

TOP RING FEATURES

- Shell molded
- High tensile strength
- Withstands extreme temperatures
- Virtually unbreakable
- Impact resistant plasma moly alloy



RING DESIGN TOP RING: DUCTILE IRON, PLASMA MOLY
 SECOND RING: CAST IRON, REVERSE TORSIONAL TWIST | OIL RING: FLEX-VENT

1/16"- 1/16"- 3/16" STD. TENSION

BORE SIZE	SET #
3.7800	43M5527 STD
3.8000	43M5527 .020
3.8100	43M5527 .030
3.8150	43M5527 .035
3.8200	43M5527 .040
3.8250	43M5527 .045
THE ABOVE ARE 4 CYLINDER SETS	
3.7360	43M5567 STD
3.7710	43M5567 .035
3.9100	43M5575 STD
3.9400	43M5575 .030
3.9500	43M5575 .040
3.9700	43M5575 .060
4.0000	43M5523 STD
4.0050	43M5523 .005
4.0100	43M5523 .010
4.0200	43M5523 .020
4.0250	43M5523 .025
4.0300	43M5523 .030
4.0350	43M5523 .035
4.0400	43M5523 .040
4.0450	43M5523 .045
4.0500	43M5525 STD
4.0550	43M5525 .005
4.0600	43M5523 .060
4.0650	43M5523 .065
4.0800	43M5523 .080
4.0800	43M5525 .030
4.0850	43M5525 .035
4.1100	43M5525 .060
4.1150	43M5525 .065
4.1200	43M5590 STD
4.1250	43M5529 STD
4.1300	43M5529 .005
4.1350	43M5529 .010
4.1450	43M5529 .020
4.1500	43M5529 .025
4.1510	43M5543 STD
4.1550	43M5543 .005
4.1550	43M5529 .030
4.1550	43M5590 .035
4.1600	43M5529 .035
4.1650	43M5542 STD
4.1650	43M5529 .040
4.1650	43M5590 .045
4.1700	43M5542 .005
4.1700	43M5529 .045
4.1800	43M5543 .030

BORE SIZE	SET #
4.1850	43M5529 .060
4.1900	43M5529 .065
4.1950	43M5542 .030
4.2100	43M5542 .045
4.2150	43M5543 .065
4.2300	43M5542 .065
4.2325	43M5526 STD
4.2500	43M5519 STD
4.2550	43M5519 .005
4.2575	43M5526 .025
4.2600	43M5519 .010
4.2625	43M5526 .030
4.2700	43M5519 .020
4.2800	43M5519 .030
4.2850	43M5519 .035
4.2900	43M5519 .040
4.3100	43M5519 .060
4.3150	43M5519 .065
4.3200	43M5528 STD
4.3250	43M5528 .005
4.3425	43M5577 STD
4.3500	43M5528 .030
4.3550	43M5528 .035
4.3600	43M5528 .040
4.3600	43M5536 STD
4.3650	43M5528 .045
4.3700	43M5528 .055
4.3750	43M5577 .033
4.3750	43M5519 .125
4.3800	43M5536 .020
4.3800	43M5528 .060
4.3850	43M5528 .065
4.3900	43M5536 .030
4.3950	43M5536 .035
4.4000	43M5536 .040
4.4250	43M5536 .065
4.4400	43M5536 .080
4.4450	43M5536 .085
4.4675	43M5537 STD
4.4715	43M5537 .004
4.5000	43M5589 STD
4.5050	43M5589 .005
4.5300	43M5589 .030
4.5350	43M5589 .035
4.5600	43M5589 .060
4.5650	43M5589 .065
4.6000	43M5589 .100
4.6050	43M5589 .105

1/16"- 1/16"- 3/16" LOW TENSION

BORE SIZE	SET #
4.0000	43M5505 STD
4.0050	43M5505 .005
4.0100	43M5505 .010
4.0300	43M5505 .030
4.0350	43M5505 .035
4.0450	43M5505 .045
4.0600	43M5505 .060
4.0650	43M5505 .065
4.1250	43M5510 STD
4.1300	43M5510 .005
4.1500	43M5510 .025
4.1550	43M5510 .030
4.1600	43M5510 .035
4.1650	43M5510 .040
4.1700	43M5510 .045
4.1850	43M5510 .060
4.2500	43M5515 STD
4.2800	43M5515 .030
4.2850	43M5515 .035
4.3100	43M5515 .060
4.3150	43M5515 .065
4.3750	43M5515 .125
4.3200	43M5520 STD
4.3500	43M5520 .030
4.3550	43M5520 .035
4.5000	43M5596 STD
4.5050	43M5596 .005
4.5300	43M5596 .030
4.5350	43M5596 .035
4.5600	43M5596 .060
4.5650	43M5596 .065
4.6000	43M5596 .100
4.6050	43M5596 .105



PREMIUM DUCTILE PLASMA MOLY CONTINUED

RING DESIGN TOP RING: DUCTILE IRON, PLASMA MOLY

SECOND RING: CAST IRON, REVERSE TORSIONAL TWIST | OIL RING: FLEX-VENT

1/16"- 1/16"- 1/8" STD. TENSION

BORE SIZE	SET #
3.8750	43M5522 STD
3.8800	43M5522 .005
3.9100	43M5522 .035
3.9400	43M5522 .065
4.0000	43M5521 STD
4.0050	43M5521 .005
4.0100	43M5521 .010
4.0200	43M5521 .020
4.0250	43M5521 .025
4.0300	43M5521 .030
4.0350	43M5521 .035
4.0400	43M5521 .040
4.0450	43M5521 .045
4.0600	43M5521 .060
4.0650	43M5521 .065
4.1250	43M5501 STD*
4.1300	43M5501 .005*
4.1550	43M5501 .030*
4.1600	43M5501 .035*

*Oil ring depth on #43M5501 is .175"

1.5 - 1.5 - 3.0MM LOW TENSION

BORE SIZE	SET #
4.0000	43M5540 STD
4.0050	43M5540 .005
4.0250	43M5540 .025
4.0300	43M5540 .030
4.0350	43M5540 .035
4.0400	43M5540 .040
4.0450	43M5540 .045
4.0600	43M5540 .060
4.0650	43M5540 .065
4.0850	43M5540 .085
4.1250	43M5581 STD
4.1300	43M5581 .005
4.1450	43M5581 .020
4.1550	43M5581 .030
4.1600	43M5581 .035
4.1700	43M5581 .045
4.1900	43M5581 .065
4.2500	43M8569 STD
4.2800	43M8569 .030
4.5000	43M8525 STD

1/16"- 1/16"- 3.0MM LOW TENSION

BORE SIZE	SET #
4.0000	43M5538 STD
4.0050	43M5538 .005
4.0100	43M5538 .010
4.0200	43M5538 .020
4.0250	43M5538 .025
4.0300	43M5538 .030
4.0350	43M5538 .035
4.0400	43M5538 .040
4.0450	43M5538 .045
4.0600	43M5538 .060
4.0650	43M5538 .065
4.0750	43M5538 .075
4.0850	43M5538 .085
4.1250	43M5539 STD
4.1300	43M5539 .005
4.1350	43M5539 .010
4.1550	43M5539 .030
4.1600	43M5539 .035
4.1650	43M5539 .040

1/16"-5/64"-5/32" STD. TENSION

BORE SIZE	SET #
3.1875	43M5545 STD
3.1925	43M5545 .005

THE ABOVE ARE 4 CYLINDER SETS

1.5 - 1.5 - 4.0 MM STD. TENSION

BORE SIZE	SET #
4.0000	43M5535 STD
4.0300	43M5535 .030

5/64"- 5/64"- 3/16" LOW TENSION

BORE SIZE	SET #
3.7360	43M5548 STD
3.7810	43M5548 .045
4.0000	43M5504 STD
4.0300	43M5504 .030
4.0400	43M5504 .040
4.0450	43M5504 .045
4.2500	43M5514 STD
4.2800	43M5514 .030
4.3100	43M5514 .060

5/64"- 5/64"-3/16" STD. TENSION

BORE SIZE	SET #
4.0000	43M5502 STD
4.0200	43M5502 .020
4.0300	43M5502 .030
4.0600	43M5502 .060

THE ABOVE ARE 4 CYLINDER SETS

3.7360	43M5547 STD
4.0000	43M5508 STD
4.0050	43M5508 .005
4.0200	43M5508 .020
4.0250	43M5508 .025
4.0300	43M5508 .030
4.0350	43M5508 .035
4.0400	43M5508 .040
4.0400	43M5561 STD
4.0450	43M5508 .045
4.0600	43M5508 .060
4.0625	43M5511 STD
4.0650	43M5508 .065
4.0675	43M5511 .005
4.0700	43M5561 .030
4.0925	43M5512 STD
4.0975	43M5511 .035
4.0975	43M5512 .005
4.1250	43M5513 STD
4.1250	43M5512 .030
4.1300	43M5513 .005
4.1500	43M5513 .025
4.1550	43M5512 .060
4.1550	43M5513 .030
4.1600	43M5513 .035
4.1650	43M5513 .040
4.1700	43M5513 .045
4.1850	43M5513 .060
4.1900	43M5513 .065
4.2500	43M5518 STD
4.2550	43M5518 .005
4.2800	43M5518 .030
4.2850	43M5518 .035
4.2900	43M5518 .040
4.3100	43M5518 .060
4.3150	43M5518 .065



STEEL CHROME BARREL FACE TOP RINGS

TOP RING FEATURES

- Impact resistant chrome coated steel alloy
- Designed for most demanding high compression applications
- Alloy steel
- Reduced side wear and extended life
- High stress and high temperature conditions

RING DESIGN TOP RING: BARREL FACED STEEL, CHROME COATED STEEL ALLOY
 SECOND RING: CAST IRON, REVERSE TORSIONAL TWIST | OIL RING: FLEX-VENT

1.2-1.2-3.0MM LOW TENSION	
BORE SIZE	SET #
3.455	43SC5556 STD
3.455	43SC5556 .010
3.4650	43SC5556 .020
3.4750	43SC5556 .030
3.4850	43SC5556 .040
3.5050	43SC5556 .060

THE ABOVE ARE 4 CYLINDER SETS

1.2-1.5-2.8MM STD. TENSION	
BORE SIZE	SET #
2.9530	43SC5558 STD
2.9630	43SC5558 .010
2.9730	43SC5558 .020
2.9830	43SC5558 .030
2.9930	43SC5558 .040
3.0130	43SC5558 .060

THE ABOVE ARE 4 CYLINDER SETS

1.0-1.5-2.8MM STD. TENSION	
BORE SIZE	SET #
3.1890	43SC5572 STD
3.1990	43SC5572 .010
3.2090	43SC5572 .020
3.2190	43SC5572 .030
3.2290	43SC5572 .040
3.3070	43SC8513 STD
3.3275	43SC8513 .020

THE ABOVE ARE 4 CYLINDER SETS

CLAIMER MOLY RACE RINGS

TOP RING FEATURES:

- Low friction cast iron
- Plasma moly impact resistant alloy
- Low friction wear resistant surface

RING DESIGN TOP RING: CAST IRON, PLASMA MOLY
 SECOND RING: CAST IRON, REVERSE TORSIONAL TWIST | OIL RING: FLEX-VENT

1/16"- 1/16" - 3/16" STD. TENSION	
BORE SIZE	SET #
4.000	43CM5532 STD
4.020	43CM5532 .020
4.030	43CM5532 .030
4.035	43CM5532 .035
4.040	43CM5532 .040
4.060	43CM5532 .060
4.065	43CM5532 .065
4.125	43CM5534 STD
4.145	43CM5534 .020
4.155	43CM5534 .030
4.165	43CM5534 .040
4.250	43CM5541 STD
4.310	43CM5541 .060

1.5-1.5-4.0MM STD. TENSION	
BORE SIZE	SET #
4.000	43CM5530 STD
4.030	43CM5530 .030

5/64"-5/64"-3/16" STD. TENSION	
BORE SIZE	SET #
4.000	43CM5531 STD
4.030	43CM5531 .030
4.040	43CM5531 .040
4.060	43CM5531 .060
4.125	43CM5533 STD
4.155	43CM5533 .030

1/16"-1/16"-1/8" STD. TENSION	
BORE SIZE	SET #
4.000	43CM5521 STD
4.030	43CM5521 .030
4.035	43CM5521 .035
4.040	43CM5521 .040
4.060	43CM5521 .060
4.125	43CM5501 STD
4.155	43CM5501 .030

1.5-1.5-3.0MM LOW TENSION	
BORE SIZE	SET #
4.000	43CM5540 STD
4.030	43CM5540 .030
4.060	43CM5540 .060

CLAIMER CAST RACE RINGS

TOP RING FEATURES

- Low friction cast iron
- Excellent heat transfer to the cylinder walls
- Phosphate coated
- Lubricating graphite material

RING DESIGN TOP RING: CAST IRON, PHOSPHATE COATED
 SECOND RING: CAST IRON, REVERSE TORSIONAL TWIST | OIL RING: FLEX-VENT

1/16"- 1/16"- 3/16" STD. TENSION	
BORE SIZE	SET #
4.000	43C5532 STD
4.030	43C5532 .030
4.040	43C5532 .040
4.060	43C5532 .060
4.125	43C5534 STD
4.155	43C5534 .030
4.165	43C5534 .040
4.185	43C5534 .060

5/64"-5/64"-3/16" STD. TENSION	
BORE SIZE	SET #
4.030	43C5531 .030



HARDWARE KITS

APPLICATION	PART #
CHEVROLET	
SMALL BLOCK 1957-94, 348-409 1958-65	29-1000
BIG BLOCK 1965-90	29-1001
LS 4.8L-5.3L-5.7L-6.0L 1999-00	29-1006
LS 4.8L-5.3L-5.7L-6.0L-6.2L-7.0L 2001-13	29-1007
CHRYSLER	
345 (5.7L), 370 (6.1L), 392 (6.4L) LATE HEMI 2003-ON	29-1203
361, 383, 400, 426, 440 1-BOLT AND 3-BOLT CAM BOLTS	29-1200
FORD	
260-289-302-351W, 351C-351M-400	29-1300
BIG BLOCK 429-460	29-1302
2-PIECE FUEL PUMP ECCENTRIC FOR ABOVE KITS	29-3035K
PONTIAC	
301-455	29-1004

No more searching for hardware! Top quality dowels, camshaft and oil filter bolts, woodruff keys, camshaft lock plate and .400" bellhousing dowels are all put together in a convenient package.



BELL HOUSING TO BLOCK DOWELS

Pair of .400" extra length (1.550 total length) solid steel dowels

APPLICATION	PART #
CHEVROLET SMALL BLOCK AND BIG BLOCK V8	29-2000-2
FITS MANY GM APPLICATIONS	



ALUMINUM REAR MAIN SEAL HOUSING KIT

APPLICATION	PART #
CHEVROLET LS GEN III & IV 4.8L-6.2L	29-9250K
HOUSING, SEAL AND BOLT KIT	OEM 12639250



BILLET ALUMINUM REAR MAIN SEAL HOUSING

Replaces mismatch, leaky factory housing. Precision machined to properly locate seal on crankshaft centerline.

APPLICATION	PART #
CHRYSLER BIG BLOCK 383-400-413-426-440	29-9440
FULL MACHINED BILLET HOUSING AND BOLTS	
REPLACEMENT FOR OEM #P4529732	
USE WITH 2947 FLOUROELASTOMER SEAL, INCLUDED IN 31-1010MLS GASKET SET, PAGE 60	



SPIN ON OIL FILTER ADAPTER

APPLICATION	PART #
CHEVROLET V8 1967-90	29-4010
WITH CHECK VALVE	OEM 19299222



LIFTER VALLEY SCREEN KITS

- Designed to minimize damage caused by valve train and other breakage in the engine
- Keeps debris away from the engine's rotating assembly and oil pump pickup
- Reduces windage loss and aids oil control.
- Directs returning oil from the cylinder heads away from the spinning crankshaft
- Pre-formed screens are secured with high strength epoxy over oil drainback holes to catch metal fragments.
- Allen socket plugs are included for installation in the galley



APPLICATION	CONTENTS	PART #
CHEVROLET SMALL BLOCK	TWO PRESS-IN SCREENS, TWO LARGE FORMED SCREENS, EIGHT 1/4" NPT SOCKET PLUGS AND EPOXY	29-4001
CHEVROLET BIG BLOCK	ONE PRESS-IN SCREEN, TWO LONG SCREENS AND EPOXY.	29-4002

LIFTER VALLEY VENTS

Provides positive crankcase ventilation and eliminates lifter valley oil drain-through to crankshaft, which results in windage loss.

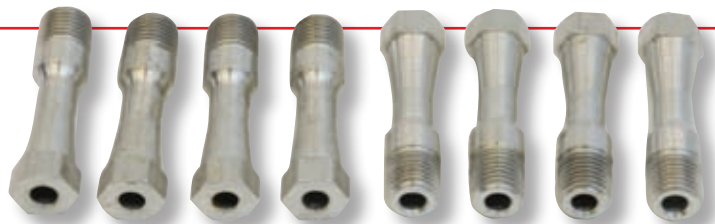

APPLICATION	DESCRIPTION	PART #
CHEVROLET SMALL BLOCK	PACKAGE OF 8 VALLEY VENTS	29-4000-8

OIL RESTRICTOR KITS

- Restricts oil to lifters on engines equipped with mechanical roller lifters and roller rocker arms
- Force more oil to engine bearings
- Consists of a pair of precision drilled restrictors
- Cut horsepower loss caused by oil windage
- SB and BB Chevrolet race engines

DESCRIPTION	APPLICATION	PART #
ALUMINUM RESTRICTOR KIT	REPLACES THE REAR BLOCK OIL GALLEY PLUGS	29-4004
STEEL RESTRICTOR KIT	SCREWED INTO THREADED OIL PASSAGES	29-4005



MAGNET KIT

Powerful magnets attract metal fragments before they reach critical areas. Can be installed in cylinder heads, intake valley and oil pans.

DESCRIPTION	APPLICATION	PART #
UNIVERSAL MAGNET KIT	4 SMALL MAGNETS, 4 LARGE MAGNETS AND EPOXY	29-4003



ENGINE PRO - FEL-PRO CO-BRANDED PERFORMANCE GASKET SETS



NOW AVAILABLE WITH MULTI-LAYER STEEL, STEEL CORE LAMINATE OR STAINLESS STEEL CORE HEAD GASKETS

Engine Pro has partnered with Fel-Pro to create an exclusive line of performance gasket sets that target the needs of the performance engine builder, with the options you need to get the job done.

These sets feature: Fel-Pro's Performance head gaskets, valve cover gaskets, exhaust header gaskets, oil pan gaskets, rear main seal and timing cover set. MLS gasket sets feature many upgraded gaskets, including flourastomer rear main seals. These sets do not include valve stem seals and intake gaskets, allowing the builder to choose. Add Engine Pro Molded Silicone oil pan and valve cover gaskets for the ultimate engine sealing set!

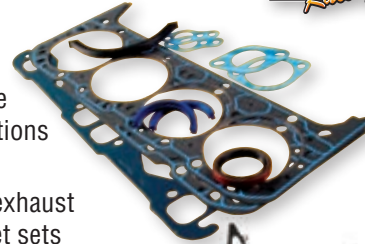

See page 61 for more information!

SETS WITH MLS HEAD GASKETS			MOLDED SILICONE GASKET UPGRADES	
APPLICATION	HEAD GSKT	PART #	OIL PAN #	VALVE COVER #
CHEVROLET				
SMALL BLOCK 1957-85 283 -350 UP TO 4.155" BORE	1143	31-1000MLS	31-1880-1	31-1628
SMALL BLOCK 1986-UP 350 1-PIECE SEAL TO 4.155" BORE	1143	31-1003MLS		
SMALL BLOCK 400 1970-80	1144	31-1004MLS	31-1880-1	31-1628
5.3L, 5.7L, LS1, LS6 UP TO 3.945" BORE	1160L/R-053	31-1006		
6.0L, 6.2L, LS2, LS3 UP TO 4.100" BORE	1161L/R-053	31-1007		
BIG BLOCK 396 - 454 1965-90 UP TO 4.370" BORE	1071-041	31-1005MLS	31-1884	31-1635
BIG BLOCK 502 GEN IV 2-PIECE SEAL BLOCKS TO 4.540" BORE	1075-041	31-1009MLS	31-1884	31-1635
CHRYSLER				
BIG BLOCK 383, 400, 426 (WEDGE), 440	26515-041	31-1010MLS	31-0998WT	
FORD				
SMALL BLOCK 1962-82 260,289,302 EXC. BOSS	1133	31-1002MLS	31-13260	31-1684

SETS WITH PERMATORQUE STEEL CORE LAMINATE HEAD GASKETS			MOLDED SILICONE GASKET UPGRADES	
APPLICATION	HEAD GSKT	PART #	OIL PAN #	VALVE COVER #
CHEVROLET				
SMALL BLOCK 1957-85 283 -350 UP TO 4.155" BORE	1003	31-1000	31-1880-1	31-1628
SMALL BLOCK 1986-UP 350 1-PIECE SEAL TO 4.155" BORE	1003	31-1003		
SMALL BLOCK 400 1970-80	1004	31-1004	31-1880-1	31-1628
BIG BLOCK 396 - 454 1965-90 UP TO 4.370" BORE	1037	31-1005	31-1884	31-1635
BIG BLOCK 502 GEN IV 2-PIECE SEAL BLOCKS TO 4.540" BORE	1047	31-1009	31-1884	31-1635
BIG BLOCK 454 1991-00 GEN V & VI 1-PIECE SEAL TO 4.370" BORE	1037	31-1016		
BIG BLOCK 502 91-ON GEN V & VI 1-PIECE SEAL TO 4.540" BORE	1047	31-1019		
FORD				
SMALL BLOCK 1962-82 260,289,302 EXC. BOSS (9333PT-1*)	1152	31-1002	31-13260	31-1684

MARINE PERFORMANCE SETS WITH PERMATORQUE STAINLESS STEEL HEAD GASKETS			MOLDED SILICONE GASKET UPGRADES	
APPLICATION	HEAD GSKT	PART #	OIL PAN #	VALVE COVER #
CHEVROLET STANDARD ROTATION				
SMALL BLOCK 1957-85 283 -350 UP TO 4.155" BORE	17030	31-1011	31-1880-1	31-1628
SMALL BLOCK 1986-UP 350 1-PIECE SEAL TO 4.155" BORE	17030	31-1013		
BIG BLOCK 396 - 454 1965-90 UP TO 4.370" BORE	17046	31-1005	31-1884	31-1635
BIG BLOCK 502 GEN IV 2-PIECE SEAL BLOCKS TO 4.540" BORE	17048	31-1009	31-1884	31-1635
BIG BLOCK 454 1991-00 GEN V & VI 1-PIECE SEAL TO 4.370" BORE	17046	31-1016		
BIG BLOCK 502 91-ON GEN V & VI 1-PIECE SEAL TO 4.540" BORE	17048	31-1019		

MOLDED SILICONE GASKETS WITH STEEL SUPPORT CARRIER



- Molded silicone rubber construction with steel support carrier allows removal and reinstallation without damaging the gasket
- Steel compression limiters prevent over tightening

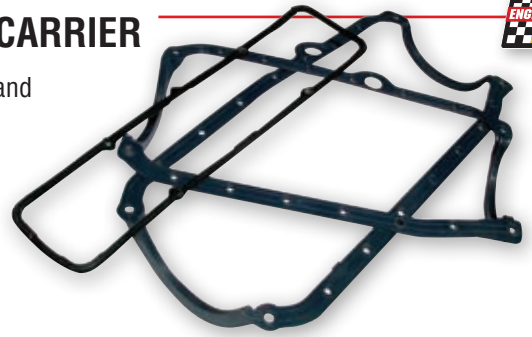

VALVE COVER GASKET SETS

APPLICATION	THICKNESS	PART #
CHEVROLET		
SMALL BLOCK (59-86)		
“STAGGERED” BOLT PATTERN,CHEVROLET 18 DEGREE AND BRODIX 12	.340 NOMINAL; .250 AT LIMITER	31-1628
SMALL BLOCK (59-86)		
“STAGGERED” BOLT PATTERN,CHEVROLET 18 DEGREE AND BRODIX 12	.200 NOMINAL; .160 AT LIMITER	31-12869T
BIG BLOCK (65-84), 3 UPPER AND 4 LOWER BOLTS	.180 NOMINAL; .140 AT LIMITER	31-1635
FORD		
SMALL BLOCK 221-351W (62-01)	.180 NOMINAL; .140 AT LIMITER	31-1684

1-PIECE OIL PAN GASKETS

APPLICATION	THICKNESS	PART #
CHEVROLET		
SMALL BLOCK, (75-85) RH OR LH DIPSTICKS, SIDE RAILS TRIMMED FOR STROKERS	.141	31-1880-1
SMALL BLOCK (86-97) RH DIP, GM BOW TIE SHORT DECK, NON-CNC BOW TIE W/2-PCE SEAL ADAPTER	.141	31-1886
BIG BLOCK (65-90)	.094	31-1884
BIG BLOCK (91-00)	.094	31-34407
FORD		
SMALL BLOCK 221-302 (62-01)	.094	31-13260

OIL PAN GASKET WITH WINDAGE TRAY

APPLICATION	PART #
CHRYSLER BIG BLOCK 383, 400, 426 WEDGE / HEMI AND 440	
STOCK CRANKSHAFTS TO 3.750" STROKE	REPLACES OEM# P4120998 31-0998WT
STROKER CRANKSHAFTS UP TO 4.150" STROKE	REPLACES OEM# P5007345 31-7345WT



LS PERFORMANCE GASKET SETS

APPLICATION	MATERIAL	DIMENSIONS	PART #
VALVE COVER GASKET SET			
LS GEN III & IV ONLY- 4.8L, 5.3L, 5.7L, 6.0L, 6.2L, 7.0L (1999-17)	MSR: SET OF 2		31-50504R
INTAKE MANIFOLD GASKET SETS			
LS1 ,LS6, GM 5.7L VIN G&S (1997-04)	MSR: SET OF 8	3.56" X 1.24"	31-11017
LS7 - 7.0L	MSR: SET OF 8	2.52" X 1.45"	31-11023
LS3,L92 - 6.2L	MSR: SET OF 8	2.90" X 1.45"	31-11024
CATHEDRAL PORTS ALL	MSR: SET OF 2	1.15" X 3.47" .200 THICK	31-11022
EXHAUST HEADER SET			
LARGE RACE PORT (DOES NOT FIT LS7)	MLS: SET OF 2	1.90" DIA. .060" THICK	31-11004
OIL PAN GASKET SET			
LS GEN III & IV - 4.8L, 5.3L ,5.7L, 6.0L, 6.2L, 7.0L (1997-17)	MSR: ON STEEL CORE		31-30693R
TIMING COVER SET			
LS GEN III & IV - 4.8L, 5.3L ,5.7L, 6.0L, 6.2L, 7.0L (1997-17)	MSR: ON ALUMINUM CORE		31-11062

NOTE: MSR = MOLDED SILICONE RUBBER | MLS = MULTI LAYER STEEL

ENGINE PRO OEM GASKETS FOR LS, LT & DURAMAX

Direct from the original equipment factory these high performance multi layered steel gaskets are the preferred choice for extreme conditions including severe duty, nitrous, supercharged and turbo applications.



GM LS AND LT MULTI LAYER STEEL HEAD GASKETS

APPLICATIONS		NOTES	PART #
LS GEN III AND GEN IV 2001-2018			
LSA / LS9 6.2L SUPERCHARGED	.055" THICK, 4.100" MAX BORE	MLS 7-LAYER	28-12622033
LS 7 7.0L NATURALLY ASPIRATED	.051" THICK, 4.140" MAX BORE	MLS 5-LAYER	28-12582179
LS3 / L92 6.0L - 6.2L NATURALLY ASPIRATED	.051" THICK, 4.080" MAX BORE	MLS 5-LAYER	28-12610046
LS2 / L76 6.0L NATURALLY ASPIRATED	.051" THICK, 4.020" MAX BORE	MLS 5-LAYER	28-12589227
LS1 / LS6 5.7L NATURALLY ASPIRATED PREV. 12573949	.051" THICK, 3.920" MAX BORE	MLS 3-LAYER	28-12589226
L59 / LM7 4.8L - 5.3L NATURALLY ASPIRATED	.052" THICK, 3.850" MAX BORE	MLS 5-LAYER	28-12575329
LT GEN V 2016-2020			
L8T 6.6L NATURALLY ASPIRATED 2020-ON	.054" THICK, 4.094" MAX BORE	MLS 7-LAYER	28-12688186
LT4 / LT5 / Z06 / ZL1 / ZR1 6.2L W & WO / SUPERCHARGER	.055" THICK, 4.100" MAX BORE	MLS 7-LAYER	28-12654622
LT1 / L86 6.2L NATURALLY ASPIRATED PREV. 12659260	.054" THICK, 4.094" MAX BORE	MLS 7-LAYER	28-12688943
L83 / L8B / L84 / L82 5.3L NATURALLY ASPIRATED	.054" THICK, 3.840" MAX BORE	MLS 7-LAYER	28-12622325

ADDITIONAL GASKET APPLICATIONS

APPLICATIONS		NOTES	PART #
CAMSHAFT RETAINER PLATE	W/RECESSED BOLT HOLES		08-12589016
VALVE COVER	LS EXC. 1997-98 W/PERIMETER BOLTS	2 REQUIRED	31-12637683
VALLEY COVER NON-AFM PRE. 12550607	5.3, 5.7, 6.0L, LS1, LS6, LQ9	1997-05	31-12558178
VALLEY COVER NON-AFM PRE. 12574467	5.3-6.0-6.2, LS2, LS3, LSA, L92	2005-13	31-12610141
MLS EXHAUST MANIFOLD	LS-SERIES ENGINES - ALL	2 REQUIRED	31-12617944
REAR MAIN HOUSING	LS-SERIES ENGINES - ALL		31-12639249
TIMING COVER	LS-SERIES ENGINES - ALL		31-12633904
WATERPUMP PRE. 12610311	LS-SERIES ENGINES - ALL	2 REQUIRED	31-12630223
OIL PAN	LS-SERIES EXCEPT LS7 AND LS9		31-12612350
OIL PAN	LS-SERIES LS7 AND LS9 ONLY	FACTORY DRY SUMP	31-12612351
OIL PICK UP SCREEN SEAL (RED)	LS-SERIES ENGINES - ALL	10-PACK	31-12584922
REAR MAIN SEAL ONLY	LS-SERIES ENGINES - ALL		39-89060436
TIMING COVER SEAL PREV. 12615300	LS-SERIES ENGINES - ALL		39-12585673

GM DURAMAX HEAD GASKETS

APPLICATION		DRIVER SIDE #	PASSENGER SIDE #
6.6L DIESEL 2001-2016	"A"-.037" - 0.95MM THICK MLS	28-12637787	28-12637790
	"B"-.039" - 1.00MM THICK MLS	28-12637786	28-12637789
	"C"-.041" - 1.05MM THICK MLS	28-12637785	28-12637788

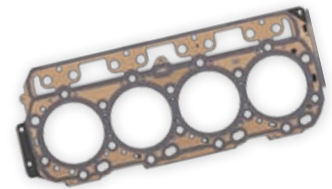

Please Refer To Our GM LS And LT Cylinder Head Gasket Chart On Pages 63

HEAD BOLT SETS

APPLICATION		PART #
CHEVROLET		
265-400 C.I. 1955-1994	TRADITIONAL TORQUE BOLTS WITH 5/8" HEX HEAD	38-350N
305-350 C.I. VORTEC 1994-2000	TORQUE-TO-YIELD WITH 1/2" HEX HEAD	38-3101
SMALL BLOCK V8 1955-2000	HIGH PERFORMANCE 180,000 PSI WITH 1/2" HEX HEAD	38-350HP



GM LS AND LT CYLINDER HEAD GASKET CHART



ENGINE CODE	VIN CODE	POWER	SIZE	BORE (IN)	STROKE (IN)	STANDARD THICKNESS (IN)	STANDARD BORE (IN)	VOLUME (CC)	INTERCHANGE	PART#
L20	A	260-302	4.8L	3.780	3.300	0.051	3.937	10.2	OE# 12589226	28-12589226
LY2	C	260-295	4.8L	3.780	3.300				26190 PT/54442	
L33	B	310	5.3L	3.780	3.620					
LC9	3/7	315-320	5.3L	3.780	3.620					
LFT			5.3L	3.780	3.620					
LH6	M	300-315	5.3L	3.780	3.620					
LH8	L	300	5.3L	3.780	3.620					
LH9	P	300	5.3L	3.780	3.620					
LMF	4	301	5.3L	3.780	3.620					
LMG	0	315-320	5.3L	3.780	3.620					
LS4	C	303	5.3L	3.780	3.620					
LY5	J	315-320	5.3L	3.780	3.620					
LS1	G	305-350	5.7L	3.900	3.620					
LS6	S	385-405	5.7L	3.900	3.620					
LR4	V	255-285	4.8L	3.780	3.300	0.052	3.835	9.8	OE# 12575329	28-12575329
LM7	T	270-295	5.3L	3.780	3.620				26191 PT/54441	
L59	Z	285-295	5.3L	3.780	3.620					
LM4	P	290	5.3L	3.780	3.620					
LQ4	U	300-325	6.0L	4.000	3.620	0.051	4.039	10.7	OE# 12589227	28-12589227
LQ9	N	345	6.0L	4.000	3.620				26192 PT/54445	
LS2	U	390-400	6.0L	4.000	3.620					
LFA	5	332	6.0L	4.000	3.620					
LZ1	J	332	6.0L	4.000	3.620					
LC8	B	342-360	6.0L	4.000	3.620	0.052	4.094	11.0	OE# 12610046	28-12610046
L76	Y	361-367	6.0L	4.000	3.620				26192 PT/54660	
L77	2	362	6.0L	4.000	3.620					
L96	G	322-360	6.0L	4.000	3.620					
LY6	K	361	6.0L	4.000	3.620					
L98	H	362	6.0L	4.000	3.620					
LS3	W	426-436	6.2L	4.065	3.620					
L99	J	400	6.2L	4.065	3.620					
L94	F	403	6.2L	4.065	3.620					
L92	8	403	6.2L	4.065	3.620					
L9H	2	403	6.2L	4.065	3.620					
LS9	R/T	638	6.2L	4.065	3.620	0.055	4.094	11.9	OE# 12622033	28-12622033
LSA	P	556-580	6.2L	4.065	3.620				54983	
LS7	E	505	7.0L	4.125	4.000	0.051	4.154	11.3	OE# 12582179	28-12582179
									54446	
L83	C	355-376	5.3L	3.780	3.620	0.054	3.835	10.2	OE# 12622325	28-12622325
L8B	R	355-380	5.3L	3.780	3.620				26744PT/54996	
L84	D	354	5.3L	3.780	3.620					
L82	F	355	5.3L	3.780	3.620					
LT1	7	455-460	6.2L	4.060	3.620	0.054	4.094	11.6	OE# 12688943	28-12688943
LT2		490-495	6.2L	4.060	3.620					
L86	J	420	6.2L	4.060	3.620					
L87		420	6.2L	4.060	3.620					
LT4		640-650	6.2L	4.060	3.620	0.055	4.094	11.9	OE# 12654622	28-12654622
LT5		755	6.2L	4.060	3.620					
L8T	31	401	6.6L	4.060	3.850	0.054	4.094	11.6	OE# 12688186	28-12688186

ENGINE PRO ENGINE ENAMEL

Engine Pro has what you need to build and repair engines—from start to finish. For paints, cleaners and specialty lubricants, turn to the pro...Engine Pro

- Provides a tough finish that resists heat and gasoline
- Fast drying
- Protects engines, transmissions and other O.E.M. equipment
- Heat resistant to 300 degrees F

APPLICATION		PART #
CHRYSLER		
BLUE		EN-63
HEMI ORANGE		EN-76
RED		46-440
FORD		
BLUE		46-460
GREY		46-430
MERCURY BLUE		46-560
RED		46-440N
GM		
BLACK		46-115
BLUE		EN-67
PONTIAC METALLIC BLUE		46-389
CHEVY ORANGE		46-480
CADILLAC GOLD		EN-50
CUMMINS		
BEIGE		EN-73
DETROIT		
ALPINE GREEN		EN-60
UNIVERSAL		
GLOSS BLACK		46-115
SATIN BLACK		46-139
FLAT BLACK		16-133
STAINLESS STEEL		46-054
UNIVERSAL SILVER		46-410
CAST BLAST		46-048
CAST ALUMINUM		46-710
ALUMI BLAST		46-055
CLEAR PLASTIC		16-2411

PRIMER

- Provides Maximum Rust Protection and Adhesion for a Finishing Top Coat
- Fast Drying
- For Use with Enamel, Lacquer and Acrylic Paints
- Excellent Resistance to Heat and Corrosion



ENGINE PRO VIDEO ON
PAINTS & COATINGS



HIGH HEAT PAINT

- Withstands Continuous Temperatures of up to 1200 degrees F
- Porcelain Type Bond is Formed at High Temperatures
- Resists Blistering, Peeling and Discoloration

DESCRIPTION		PART #
BLACK		16-1203
ALUMINUM		16-1201
WHITE		16-1202
CAST IRON GREY		16-2668

RUST PROOF PAINT

- Inhibits Rust
- Resists Heat and Gasoline
- Fast Drying
- Resists Chipping and Peeling

DESCRIPTION		PART #
SAFETY YELLOW		16-116
SAFETY BLUE		16-129
LIGHT GREY		620-1416

OTHER PAINTS & COATINGS

DESCRIPTION		PART #
CLEAR ACRYLIC COATING		16-121
UNDERCOATING & SOUND INSULATOR		20-046
SUPREME BLACK SHIELD PAINT		620-1415
SUPREME HUNTER GREEN SHIELD PAINT		620-1449
RED EPOXY COATING		620-1525
BLUE LAYOUT FLUID (8OZ BOTTLE W/DAUBER)		40-4410B
RED LAYOUT FLUID (8OZ BOTTLE W/DAUBER)		40-4410R
BLUE LAYOUT FLUID (200Z AEROSOL CAN)		620-1558

DESCRIPTION		PART #
ZINC RICH		16-1445
LIGHT GREY		46-831
BLACK		16-828
RED OXIDE		16-807

HI-ZINC LIQUID ENGINE ASSEMBLY LUBE

- Contains rust and oxidation inhibitors
- Extreme Pressure (EP) agents work in unison for superior protection during start up
- Contains ZDDP and EP additives
- Exceeds all OE specifications as an engine lubricant
- Guards against camshaft and lifter wear
- Adheres to metal surfaces



DESCRIPTION	PART #
ASSEMBLY LUBE, 8 OZ. BOTTLE	40-1100

MOLY ASSEMBLY LUBE

- Guards against camshaft and lifter wear
- Rust and oxidation inhibitors extreme pressure lube
- Great for rod bolt installation
- Contains molybdenum disulfide, ZDDP and other
- Anti-seize and anti-galling formula lubricating solids



DESCRIPTION	PART #
ASSEMBLY LUBE, 10 OZ. BOTTLE	40-1000

HI-ZINC ENGINE PROTECTOR

- Provides protection against camshaft, lifter and valve train damage
- Dramatically reduces friction and engine wear
- For classic and other cars with flat tappet cams without catalytic convertors
- Higher concentration of (ZDDP) for crucial break-in period
- Designed to allow piston rings to seat properly when used during engine break-in
- Prevents scuffing and galling



DESCRIPTION	PART #
HI-ZINC ENGINE PROTECTOR, 4 OZ. BOTTLE	40-1900

DRY GRAPHITE LUBE

- Dry film bonds to surface
- Good lubrication at high temperatures (850°f/454°c)
- Extends parts life

DESCRIPTION	PART #
DRY LUBE 20 OZ AEROSOL CAN	40-1506



LUBRICANTS	SIZE	PART #
DRY FILM LUBE	20 OZ AEROSOL CAN	620-1500
PENETRATING OIL	20 OZ AEROSOL CAN	620-1543

NON-CHLORINATED BRAKE & PARTS CLEANER

- Rapid air dry - voc compliant
- Can be used to eliminate disc brake squeal
- Safely remove contaminants from non rubber parts

SIZE	PART #
NON-CHLORINATED 20 OZ AEROSOL CAN	40-1548

CARB & CHOKE CLEANER

- Ideal for all carburetors, pcv valves, automatic chokes, heat risers
- Quick acting –penetrates dirt, gum, oil, etc.
- Extension tube furnished for pin point application

DESCRIPTION	PART #
CLEANER 20 OZ AEROSOL CAN	40-1536



HEAT TABS

- For high temperature gas engines
- Center melts at 250° to 255°F, 121° to 124°C

DESCRIPTION	PART #
100 TABS	80-1000-100



HEAD AND BLOCK BAGS

- 100 Count roll
- Clear poly
- Engine Pro Logo

DESCRIPTION	DIMENSIONS	PART #
HEAD BAG 2.5 MIL	10 X 8 X 36	Z2100-BA
BLOCK BAG 2.0 MIL	23 X 17 X 50	Z2200-BA



HONING OIL

High Performance honing and finishing fluid with extreme pressure additive package.

- Anti-Foam
- Anti-Oxidants
- Chlorine Free

DESCRIPTION	PART #
5 GALLON PAIL	5GH0
55 GALLON DRUM	55GDH0





We've assembled our own collection of useful formulas to help make your work go faster and be more accurate.

Go to <http://enginepro.com/calculators>

to find automated formulas to determine cubic inch displacement, compression ratios, SAE vs. metric conversion, HP & torque and more.

METRIC CONVERSION CHART

0.1MM = 0.00394	1MM = 0.03937	20MM = 0.78740
0.2MM = 0.00787	2MM = 0.07874	30MM = 1.18110
0.3MM = 0.01181	3MM = 0.11811	40MM = 1.57480
0.4MM = 0.01575	4MM = 0.15748	50MM = 1.96850
0.5MM = 0.01969	5MM = 0.19685	60MM = 2.36220
0.6MM = 0.02362	6MM = 0.23622	70MM = 2.75590
0.7MM = 0.02756	7MM = 0.27559	80MM = 3.14960
0.8MM = 0.03150	8MM = 0.31496	90MM = 3.54330
0.9MM = 0.03543	9MM = 0.35433	100MM = 3.93700
	10MM = 0.39370	

FRACTION to DECIMAL

1/32 = 0.0313	17/32 = 0.5313
1/16 = 0.0625	9/16 = 0.5625
3/32 = 0.0938	19/32 = 0.5938
1/8 = 0.1250	5/8 = 0.6250
5/32 = 0.1563	21/32 = 0.6563
3/16 = 0.1875	11/16 = 0.6875
7/32 = 0.2188	23/32 = 0.7188
1/4 = 0.2500	3/4 = 0.7500
9/32 = 0.2813	25/32 = 0.7813
5/16 = 0.3125	13/16 = 0.8125
11/32 = 0.3438	27/32 = 0.8438
3/8 = 0.3750	7/8 = 0.8750
13/32 = 0.4063	29/32 = 0.9063
7/16 = 0.4375	15/16 = 0.9375
15/32 = 0.4688	31/32 = 0.9688
1/2 = 0.5000	1 = 1.0000

CONVERSION FORMULAS

Multiply units in column 1 by the factor in column 2 to obtain the units in column 3

COLUMN 1	COLUMN 2	COLUMN 3
Centimeters	x 0.3937	= Inches
Cubic Centimeters	x 0.0611	= Cubic Inches
Cubic Inches	x 16.3872	= Cubic Centimeters
Inches	x 2.540	= Centimeters
Inches	x 25.400	= Millimeters
Millimeters	x 0.03937	= Inches

AUTO UNDERSIZES

STD = STD	.020" = .50 mm
.001" = .025 mm	.030" = .75 mm
.002" = .051 mm	.040" = 1.0 mm
.010" = .25 mm	.060" = 1.5 mm

WWW.ENGINEPRO.COM



ENGINE PRO PERFORMANCE PRODUCTS

New Items From Engine Pro...

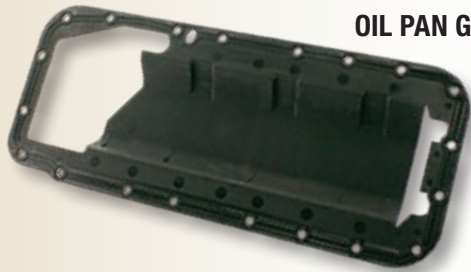

OIL PAN GASKET WITH WINDAGE TRAY

SEE PAGE 51



LS HEAD GASKETS

SEE PAGE 62

PERFORMANCE PRO-ADJUST TIMING SET

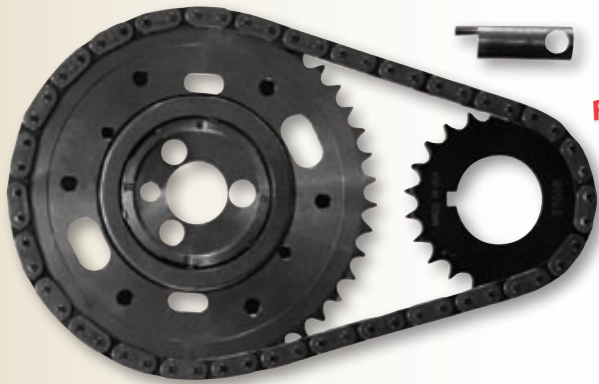

SEE PAGE 37

NITRO BLACK PERFORMANCE BEARINGS



SEE PAGE 48

NITRO BLACK
NITRIDED HIGH PERFORMANCE PARTS

ENDURANCE SERIES MECHANICAL ROLLER LIFTERS

SEE PAGE 23



REAR MAIN SEAL HOUSING KIT



SEE PAGE 58

WE ALSO CARRY

Original Equipment Replacement Products



- Piston Rings
- Rod and Main Bearings
- Timing Sets and Components
- Camshafts
- Valves
- Head Bolts
- Gaskets
- Valve Train Components

Visit our website at www.enginepro.com

DISTRIBUTED BY:

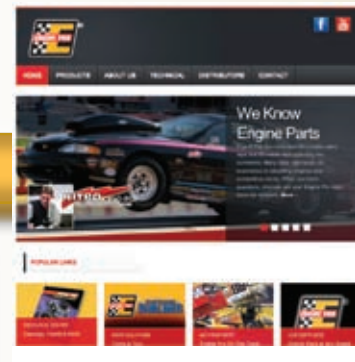

ENGINE PRO PERFORMANCE

Wheat Ridge, CO 80033

www.enginepro.com